



JDV
CONTROL
VALVES



JBF-M Type

Floating Type Metal Seat Ball Valve



*We link all you need
and more than you expect.*



**JDV
CONTROL
VALVES**

JBF-M

Floating Type Metal Seat Ball Valve

Full Bore Two-Piece Flanged Ends

JIS 10/20K ASME CLASS 150/300/600 DIN PN16/40/100

JBF-M Metal-Seat Ball Valve is designed especially for severe services with high temperature, abrasion or corrosion in the industrial processes. With JDV's self-owned coating technology, a wide range of hard faces are available to satisfy all your using conditions.

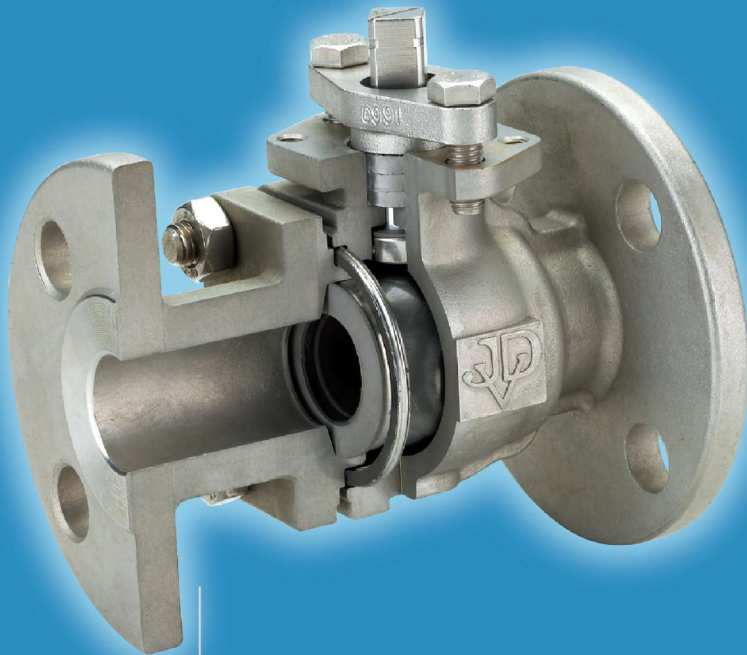

Industrial Fields:

Oil & Gas
Refinery / Petrochemical
Chemical
Pulp & Paper
Power Plant
Steel Mill
Food
Mining

Product Features

1. Highly precise machining enabling the seat leakage rate to reach FCI-70-2 Class V in standard and Class VI in option.
2. Spring-loading design keeping the seat in tight contact with the ball even at low pressure. It also offers stable valve torques under higher pressure drop.
3. Various seat designs meeting the different requirements.
4. Wide choice of hard faces satisfying the needs of all applications.
5. Oversized stem design reducing the deformation under high pressure or high temperature services.
6. Larger ball design providing the best sealing.
7. Anti-jam design of seating area precluding particles from getting stuck between the spring and the valve cap.
8. ISO 10497 Fire Safe Test certificated.
9. Anti-static design.
10. Anti-blowout stem design.

Design & Structures

Applications

1. High temperature
2. High abrasion
3. Corrosion



Seat:

Stainless Steel+Hard Face



Options:

U Type : Uni-directional Standard

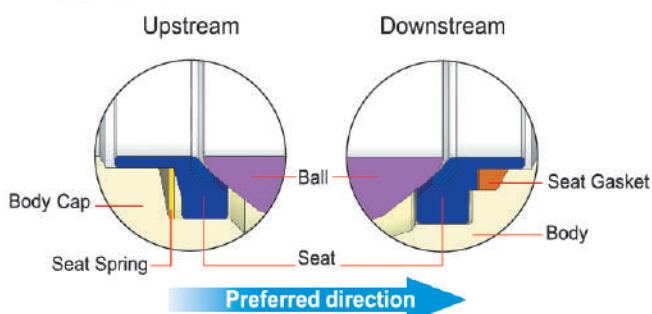

B Type : Bi-directional For backflow service

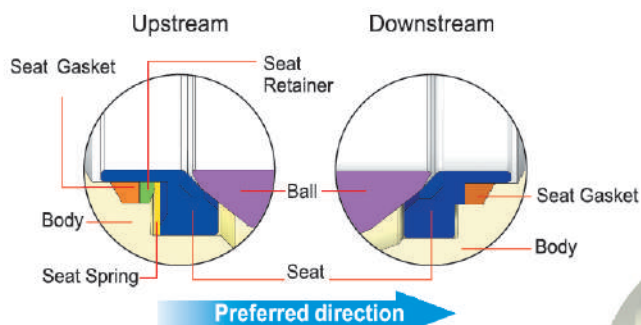

S Type : Scraper

For heavy slurry such as the black liquor in pulp & paper industry.

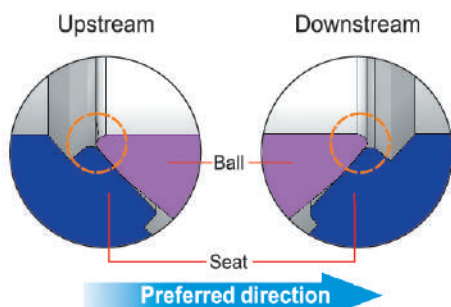

※ Downstream scraper on request for very heavy services.

Seat Spring:

Spring-loaded seat design

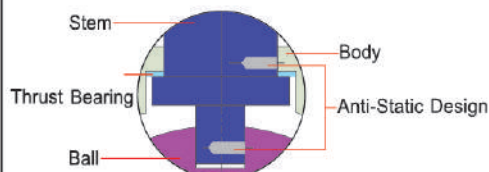

Stem:

Anti-blowout design
Anti-static design



Ball:
Stainless Steel+
Hard Face

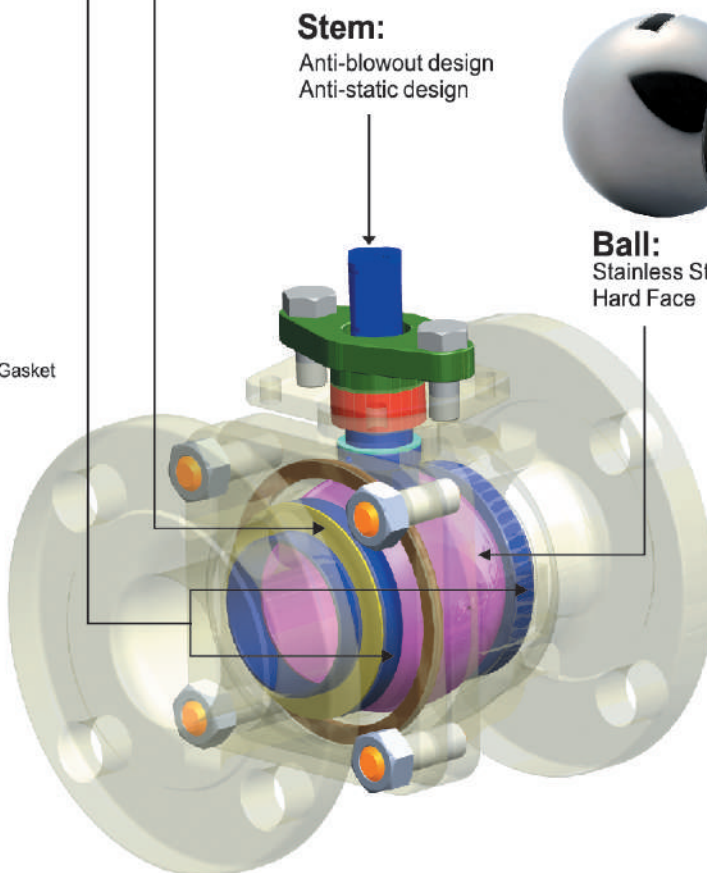

Applicable Standards

- Body material : Standard in WCB, CF8, CF8M Other materials are available according to requirements.
- Nominal size : 1/2" to 8" (DN15 to DN200)
- Pressure rating : JIS 10(20K ASME CLASS 150/300/600 DIN PN16/40/100)
- End connections : RF
- Temperature Range : -61~1202°F (-52~650°C), higher temperature on request.
- Face-to-Face Dimensions: JIS B2002 I ASME B16.10 / EN 558 Series 1/5/27
- Flanged Dimensions: JIS B2220 / ASME B16.5/EN 1092-1
- Body Pressure Testing: JIS B2D03 / ASME B16.34 API 598/ EN 12266-1
- Seat Leakage Testing : ANSI /FCI70-2
- Casting : MSS-SP-25 / MSS-SP-55
- Fire Safe Design : ISO 10497

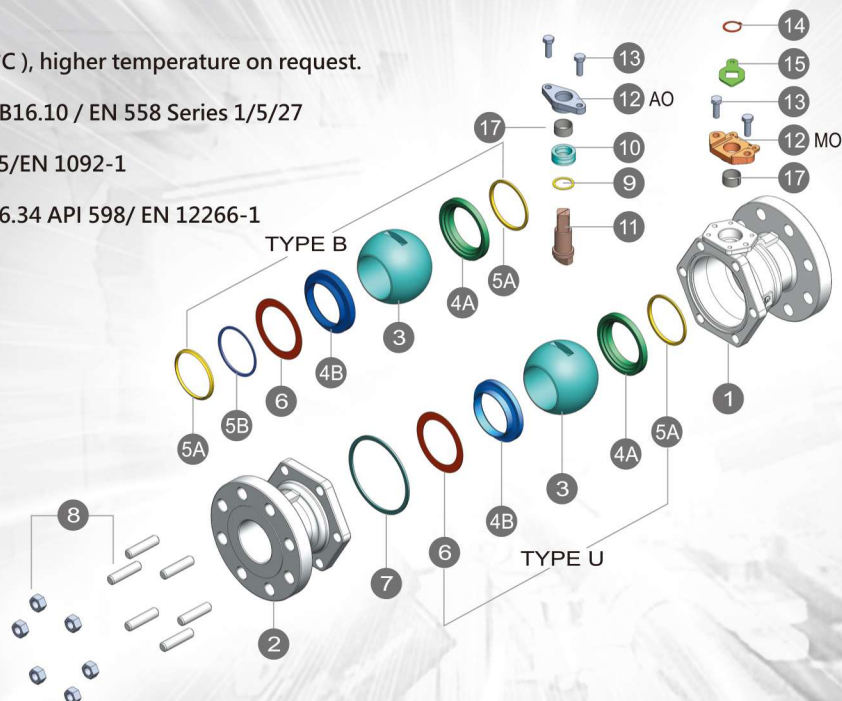

Technical Specifications

STANDARD MATERIALS

NO	SERIES PART NAME	SM -20~661°F (-29~350°C)			SH -20~797°F (-29~425°C) -20~932°F (-29~500°C)		
		A216-WCB	A351-CF8	A351-CF8M	A216-WCB	A351-CF8	A351-CF8M
1	BODY	A216-WCB	A351-CF8	A351-CF8M	A216-WCB	A351-CF8	A351-CF8M
2	CAP	A216-WCB	A351-CF8	A351-CF8M	A216-WCB	A194-A351-CF8	A351-CF8M
3	BALL	A351-CF8+HCR		A351-CF8M+HCR	A351-CF8+TC ⁽²⁾ /CRC ⁽²⁾		A351-CF8M+TC/CRC
4A	BODY SEAT	A351-CF8+STELLITE [®]		A351-CF8M+STELLITE [®]	A351-CF8+TC/CRC		A351-CF8M+TC/CRC
4B	CAP SEAT	A351-CF8+STELLITE [®]		A351-CF8M+STELLITE [®]	A351-CF8+TC/CRC		A351-CF8M+TC/CRC
5A	SEAT GASKET	GRAPHITE			GRAPHITE		
5B	SEAT RETAINER	A351-CF8		A351-CF8M	A351-CF8		A351-CF8M
6	SEAT SPRING	INCONEL X-750			INCONEL [®] X-750		
7	BODY GASKET	316SS+GRAPHITE			316SS+GRAPHITE		
8	BOLT & NUT	A193-B7 & A194-7	A193-B8 & A194-8		A193-B7 & A194-7	A193-B8 & A194-8	
9	THRUST WASHER	METAL+HARD FACE			METAL+HARD FACE		
10	GLAND PACKING	GRAPHITE			GRAPHITE		
11	STEM	A564-630(HH1150)		A6	A638-S66286		
12	GLAND ⁽¹⁾	A351-CF8			A351-CF8		
13	GLAND BOLT	STAINLESS STEEL			STAINLESS STEEL		
14	SNAP CATCH (MO)	AISI 420			AISI 420		
15	TRAVEL STOP(MO)	A240-304			A240-304		
16	HANDLE (MO)	A240-304(1/2"~1") FCD45 (1-1/2"~3") FCD45+SGP(4" AND ABOVE)					
17	GLAND BEARING	A240-316+PTFE			A240-316+PTFE		

The above materials may be changed with different using conditions.

NOTES:

(1) Options: AO: Automation / MO: Manual

(2) HCR = Hard Chrome TC = Tungsten Carbide CRC = Chrome Carbide

JBF Series-JBF-M Type

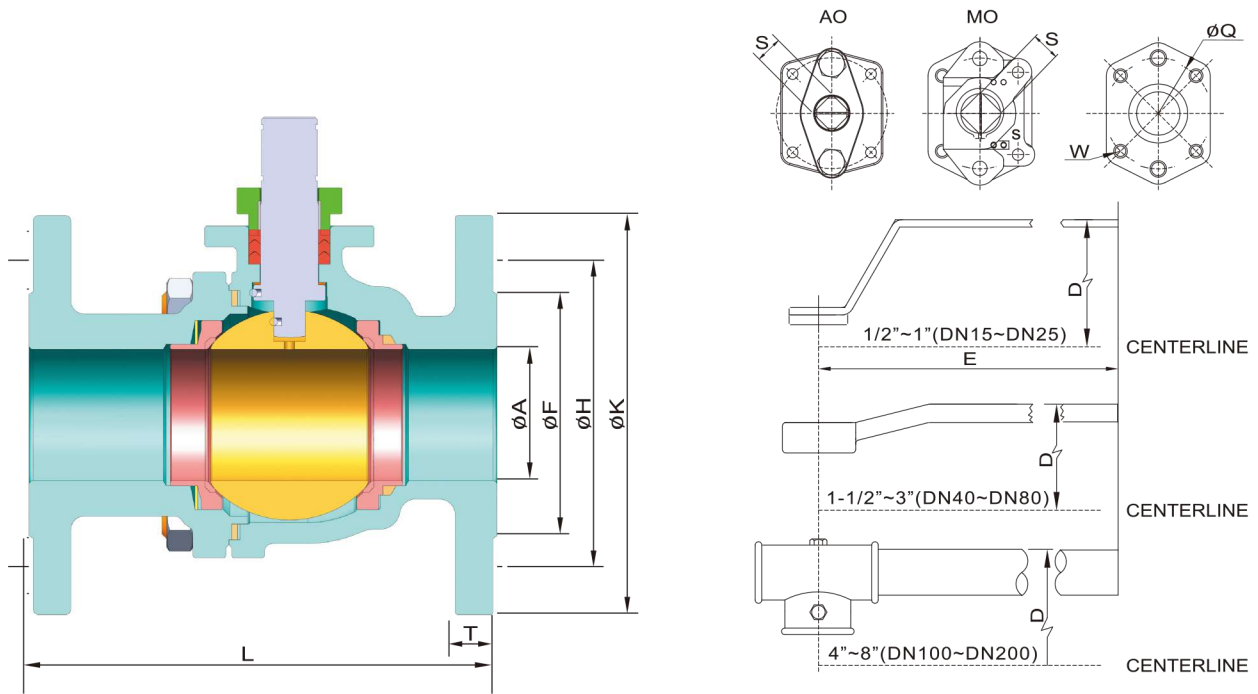

DIMENSIONS (JIS-10K)

(mm)

Size	A	F	H	K	M	N	L	T	S	Q	W	D	E	Wt (Kg)	
15	1/2"	15	51	70	95	15	4	108	12	10	42	M5	97	130	1.8
20	3/4"	20	56	75	100	15	4	117	14	10	42	M5	100	130	2.2
25	1"	25	67	90	125	19	4	127	14	12	50	M6	110	160	3.2
40	1-1/2"	38	81	105	140	19	4	165	16	17	70	M8	115	224	6.3
50	2"	50	96	120	155	19	4	178	16	17	70	M8	120	224	9.0
65	2-1/2"	65	116	140	175	19	4	190	18	20	70	M8	140	324	13.2
80	3"	76	126	150	185	19	8	203	18	20	70	M8	150	324	17.4
100	4"	100	151	175	210	19	8	229	18	27	102	M10	220	400	28.2
125	5"	125	182	210	250	23	8	356	20	27	102	M10	240	550	44.0
150	6"	150	212	240	280	23	8	394	22	32	125	M12	280	550	62.5
200	8"	200	262	290	330	23	12	457	22	35	140	M16	340	1000	128.5

DIMENSIONS (JIS-20K)

(mm)

Size	A	F	H	K	M	N	L	T	S	Q	W	D	E	Wt (Kg)	
15	1/2"	15	51	70	95	15	4	140	14	10	42	M5	97	130	2.5
20	3/4"	20	56	75	100	15	4	152	16	10	42	M5	100	130	3.5
25	1"	25	67	90	125	19	4	165	16	12	50	M6	110	160	4.9
40	1-1/2"	38	81	105	140	19	4	190	18	17	70	M8	115	224	9.8
50	2"	50	96	120	155	19	8	216	18	17	70	M8	120	224	12.2
65	2-1/2"	65	116	140	175	19	8	241	20	20	70	M8	140	324	22.4
80	3"	76	132	160	200	23	8	282	22	20	70	M8	150	324	31.2
100	4"	100	160	185	225	23	8	305	24	27	102	M10	220	400	48.0
150	6"	150	230	260	305	25	12	403	28	32	125	M12	280	550	98.3
200	8"	200	275	305	350	25	12	502	30	35	140	M16	340	1000	171.1

DIMENSIONS (ASME CLASS-150)

(mm)

Size	A	F	H	K	M	N	L	T	S	Q	W	D	E	Wt (Kg)	
15	1/2"	15	35	60.5	89	16	4	108	11.2	10	42	M5	97	130	1.8
20	3/4"	20	43	70	98	16	4	117	11.2	10	42	M5	100	130	2.2
25	1"	25	51	79.5	108	16	4	127	11.2	12	50	M6	110	160	3.2
40	1-1/2"	38	73	98.5	127	16	4	165	14.3	17	70	M8	115	224	6.3
50	2"	50	92	120.5	152	19	4	178	15.9	17	70	M8	120	224	9.0
65	2-1/2"	65	105	139.5	178	19	4	190	17.5	20	70	M8	140	324	13.2
80	3"	76	127	152.5	190	19	4	203	19.1	20	70	M8	150	324	17.4
100	4"	100	157	190.5	229	19	8	229	23.9	27	102	M10	220	400	28.2
125	5"	125	186	216	254	22	8	356	23.9	27	102	M10	240	550	44.0
150	6"	150	216	241.5	279	22	8	394	25.4	32	125	M12	280	550	62.5
200	8"	201	270	298.5	343	22	8	457	28.6	35	140	M16	340	1000	128.5

The weight refers to bare shaft valves.



JDV CONTROL VALVES

DIMENSIONS (ASME CLASS-300)

(mm)

SIZE		A	F	H	K	M	N	L	T	S	Q	W	D	E	Wt (Kg)
15	1/2"	15	35	66.5	95	16	4	140	14.3	10	42	M5	97	130	2.5
20	3/4"	20	43	82.5	117	19	4	152	15.9	10	42	M5	100	130	3.5
25	1"	25	51	89	124	19	4	165	17.5	12	50	M6	110	160	4.9
40	1-1/2"	38	73	114.5	156	22	4	190	20.7	17	70	M8	115	224	9.8
50	2"	50	92	127	165	19	8	216	22.3	17	70	M8	120	224	12.2
65	2-1/2"	65	105	149	190	22	8	241	25.4	20	70	M8	140	324	22.4
80	3"	76	127	168	210	22	8	282	28.6	20	70	M8	150	324	31.2
100	4"	100	157	200	254	22	8	305	31.8	27	102	M10	220	400	48.0
125	5"	125	186	235	280	22	8	381	35.2	32	125	M12	260	550	67.1
150	6"	150	216	270	318	22	12	403	36.6	32	125	M12	280	550	98.3
200	8"	201	270	330	381	25	12	502	41.2	35	140	M16	340	1000	171.1

DIMENSIONS (ASME CLASS-600)

(mm)

SIZE		A	F	H	K	M	N	L	T	S	Q	W	D	E	Wt (Kg)
15	1/2"	15	35	66.5	95	16	4	165	20.9	10	42	M5	97	130	2.6
20	3/4"	20	43	82.5	117	19	4	190	22.3	10	42	M5	100	130	4.0
25	1"	25	51	89	124	19	4	216	23.9	12	50	M6	110	160	5.9
40	1-1/2"	38	73	114.5	156	22	4	241	28.7	17	70	M8	115	224	11.8
50	2"	50	92	127	165	19	8	292	31.8	17	70	M8	130	224	16.9
65	2-1/2"	65	105	149.5	191	22	8	330	35	22	102	M10	190	324	29.9
80	3"	76	127	168	210	22	8	356	38.2	22	102	M10	200	324	36.0
100	4"	100	157	216	273	25	8	432	44.5	27	125	M12	240	550	67.0

DIMENSIONS (DIN PN16)

(mm)

SIZE	A	F	H	K	M	N	L		T	S	Q	W	D	E	Wt (Kg)	
							S1	S27							S1	S27
DN 15~DN 50 USE PN40																
65	2-1/2"	65	122	145	185	18	8	290	170	18	20	70	M8	140	324	14.9 13.2
80	3"	76	138	160	200	18	8	310	180	20	20	70	M8	150	324	19.4 17.4
100	4"	100	158	180	220	18	8	350	190	20	27	102	M10	220	400	32.1 28.2
150	6"	150	212	240	285	22	8	480	350	22	32	125	M12	280	550	67.9 62.5
200	8"	201	268	295	340	22	12	600	400	24	35	140	M16	340	1000	141 128.5

DIMENSIONS (DIN PN40)

(mm)

SIZE	A	F	H	K	M	N	L		T	S	Q	W	D	E	Wt (Kg)	
							S1	S27							S1	S27
15	1/2"	15	45	65	95	14	4	130	115	16	10	42	M5	97	130	2.6 2.5
20	3/4"	20	58	75	105	14	4	150	120	18	10	42	M5	100	130	3.6 3.5
25	1"	25	68	85	115	14	4	160	125	18	12	50	M6	110	160	5.2 4.9
40	1-1/2"	38	88	110	150	18	4	200	140	18	17	70	M8	115	224	10.4 9.8
50	2"	50	102	125	165	18	4	230	150	20	17	70	M8	120	224	13.0 12.2
65	2-1/2"	65	122	145	185	18	8	290	170	22	20	70	M8	140	324	24.4 22.4
80	3"	76	138	160	200	18	8	310	180	24	20	70	M8	150	324	37.7 31.2
100	4"	100	162	190	235	22	8	350	190	24	27	102	M10	220	400	52.3 48.0
150	6"	150	218	250	300	26	8	480	350	28	32	125	M12	280	550	104.8 98.3
200	8"	201	285	320	375	30	12	600	400	34	35	140	M16	340	1000	187.4 171.1

DIMENSIONS (DIN PN100)

(mm)

SIZE	A	F	H	K	M	N	L		T	S	Q	W	D	E	Wt (Kg)
							S5	S5							
15	1/2"	15	45	75	105	14	4	165	20	10	42	M5	63	130	2.6
25	1"	25	68	100	140	18	4	216	24	12	50	M6	76	160	4.0
40	1-1/2"	38	88	125	170	22	4	241	26	17	70	M8	88	224	5.9
50	2"	50	102	145	195	26	4	292	28	17	70	M8	94	224	11.8
65	2-1/2"	65	122	170	220	26	8	330	30	20	102	M10	115	324	16.9
80	3"	76	138	180	230	26	8	356	32	20	102	M10	120	324	36.0
100	4"	100	162	210	265	30	8	432	36	27	125	M12	195	400	67.0

Cv VALUES

SIZE	DN15	DN20	DN25	DN40	DN50	DN65	DN80	DN100	DN125	DN150	DN200
	1/2"	3/4"	1"	1-1/2"	2"	2-1/2"	3"	4"	5"	6"	8"
Cv	27	61	114	268	501	804	1158	2118	3412	5074	9337

TEMPERATURE & PRESSURE DIAGRAM

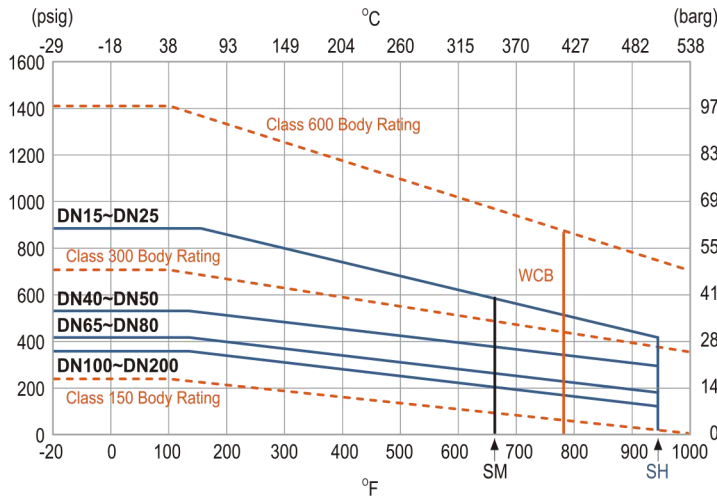

SM = MAX TEMPERATURE 661°F (350°C)
SH = MAX TEMPERATURE 932°F (500°C)
WCB = MAX TEMPERATURE 797°F (425°C)



HOW TO ORDER

JBF-M → **A** → **B** → **C** → **D** → **E** → **F** → **G**
 Ex: **JBF-M** → **C1** → **04** → **C** → **26** → **050** → **IAU** → **SH1**

A. SPECIFICATION	B. BODY MAT'L	C. BALL & SEAT MAT'L	D. STEM MAT'L	E. SIZE	F. OPTION	G. TEMPERATURE
A1 JIS 10K	02 WCB (1.0619)	A CF8	10 S31803	015 1/2"	F FIRE SAFE	SM -20~661°F(-29~350°C) BALL W/HCR SEAT W/STELLITE®
A2 JIS 20K	03 CF8 (1.4308)	C CF8M	22 630	020 3/4"	L EXTENDED STEM	SH1 -20~842°F(-29~450°C) BALL W/TC SEAT W/TC
C1 ASME CLASS 150	04 CF8M (1.4408)	D CF3	26 S66286	025 1"	I LIVE LOADING	SH2 -61~1202°F(-52~650°C) BALL W/CRC SEAT W/CRC
C2 ASME CLASS 300	05 CF3 (1.4306)	E CF3M		040 1-1/2"	H LEVER	
C3 ASME CLASS 600	06 CF3M (1.4404)	F CG8M		050 2"	G GEAR	
D2 DIN PN16	07 CG8M (1.4412)	I CD3MN		065 2-1/2"	A BARE SHAFT	
D4 DIN PN40	11 LCB (1.1138)			080 3"	U UNI-DIRECTION	
D5 DIN PN100	12 LCC (1.7219)			100 4"	B BI-DIRECTION	
	15 CD3MN (1.4470)			125 5"	S1 SINGLE SCRAPER (UPSTREAM SIDE)	
				150 6"	S2 DOUBLE SCRAPER (UPSTREAM+DOWNSTREAM)	
				200 8"		

HOW TO ORDER

※ Alternative materials are available on request.



■ HEADQUARTERS

NO. 6-1, QINGNIAN RD., YANGMEI DIST., TAOYUAN CITY 326, TAIWAN
TEL +886-3-4965066 FAX +886-3-4963526 E-MAIL: sales@jdv.com.tw



Copyright 2021/05. All rights are reserved by JDV.
The technical data and content may be changed without prior notice.