



JDV
CONTROL
VALVES

JBT-A/JBT-AM/JBT-AF/JBT-AT Type Trunnion Type **Soft Metal** Seat Ball Valve

固定軸軟密封/金屬密封球閥/固定軸全焊閥





**JDV
CONTROL
VALVES**

JBT-A/JBT-AM/JBT-AF/JBT-AT

Trunnion Type **Soft Metal** Seat Ball Valve

JDV is a leading manufacturer of valve, valve automation and measurement systems to the oil and gas industry. Our products are primarily used to control, direct and measure the flow of oil and gas as it is moved from individual wellheads through flowlines, gathering lines and transmission systems to refineries, petrochemical plants and industrial centers for processing.

Features and Benefits

Size: 2"~56" (50 mm to 1400 mm).
ASME/ANSI Class: 150~2500(PN20 to PN420)
API 2000 to 5000 psi
Forged Steel Body
Trunnion Mounted Ball
Anti-Static Device
Blow-out Proof Stem
Fire Safe Design
For Underground Use (On Request)

Applicable Standards

Design	ASME B16.34/API 6D
Face to Face	ASME B16.10/API 6D
End Flange	ASME B16.5/B16.47A
BW End	ASME B16.25
Test	API 6D / API 598
Fire Safe Test	API 607/6FA
Special	NACE MR-01-75

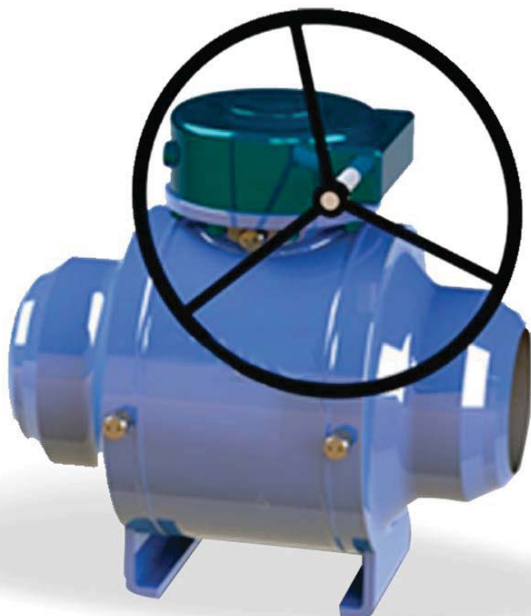

Industrial Fields:

- Oil & GAS
- Petrochemical
- Chemical
- LNG
- Crude Oil
- Refined Products Transmission Lines



Stem Seals

Delta seals and lip seals mad of PTFE are incorporated in the upper stem area. PTFE is a low-friction, non-deteriorating material that is not subjected to rapid decompression explosion. Most valve sizes have a provision for the sealant injection to establish a secondary seal.

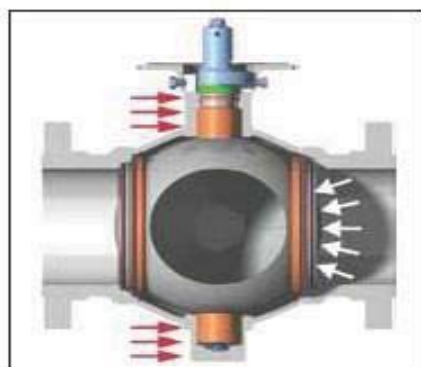

Trunnion Mounted Ball Allows Low-Torque Operation

Regardless of size or pressure rating, every JDV fully welded ball valve is trunnion mounted. High-strength forged stems are located in PTFE impregnated stainless steel bearings for smooth, accurate operations. Trunnion mounted stems absorb the thrust from line pressure, preventing excess friction between the ball and seats, so even at full rated working pressure, operating torque stays low.

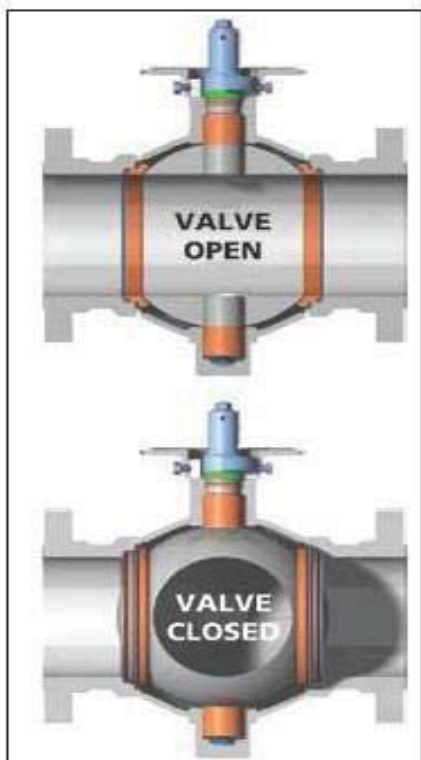

Double Block-and-Bleed

Whether in the fully open or fully closed position, pressure on each side of the ball is blocked from the body cavity by the seat ring. The body cavity can then be bled down or drained through the body port. When you block-and-bleed a JDV ball valve the following can be accomplished:

Test Valve Integrity

When the valve body is vented, the seat's integrity is verified. This test can be performed with the valve open or closed. Valve Performance can also be validated by verifying valve seat seal integrity.

Secondary Seat Seal

The sealant injection system provides a fast, simple way of restoring tight shutoff if any foreign object should damage the sealing surfaces. The injection system can also be used for routine flushing of the seat ring area in services where this may be required.

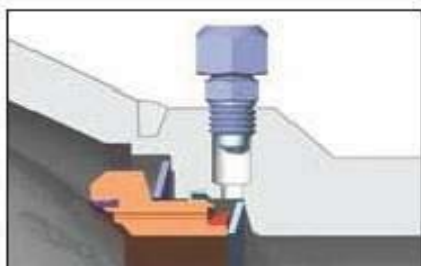

技術規範

■ 國外標準

■ ASME B16.34

閥門設計的基礎標準，規定了閥門的材料溫壓表、壁厚、檢驗要求等。

■ ASME B31.8

關於氣體輸送及配氣管道的標準，對不同材料不同壁厚的焊接有詳細的規定。

■ API 1104

管線及其設備的焊接規範，規定了管線的焊接應遵循的規定及工藝評定要求，無損檢測要求，CTOD 試驗要求等，運用其焊接工藝評定及檢驗要求可以為全焊球閥提供強而有力的依據。

■ EN 14141

天然氣管線閥門的性能要求和測試，覆蓋閥門的各種性能和試驗要求。

■ 產品結構：鍛鋼、焊接閥體、固定球。

■ 連接形式：凸面（RF）法蘭、環形槽（RTJ）法蘭、焊接端（BW）及焊接端-法蘭端。

■ 結構長度：按 API 6D 或 ANSI B16.10。

■ 壓力等級：ANSI 150 級(PN20),300 級(PN50),

400 級(PN64),600 級(PN100)，

900 級(PN150),1500 級(PN250)

■ 全通徑規格：2 “-56” (DN50- DN1400)

■ 縮徑規格：8 “-44” (DN200- DN1100)

球閥的結構及原理

典型結構示意圖

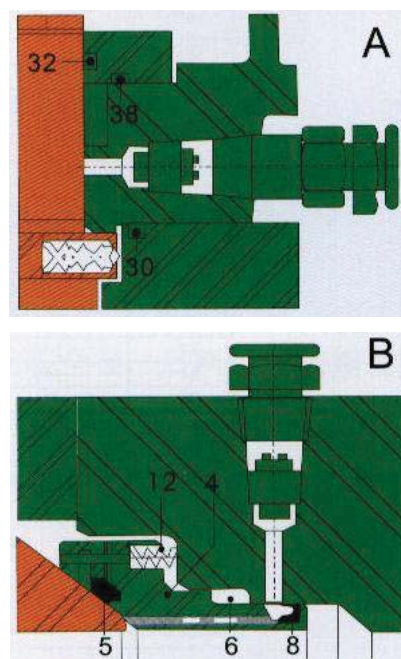
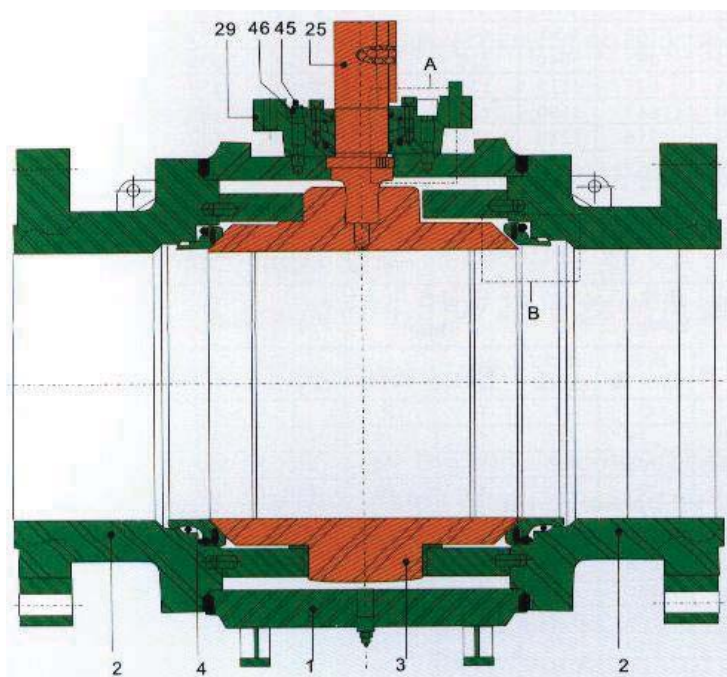

管線壓力對閥杆產生的推力

閥杆承受扭應力和彎曲應力，此種結構只適用於小口徑球閥，當口徑較大時扭矩會大大增加

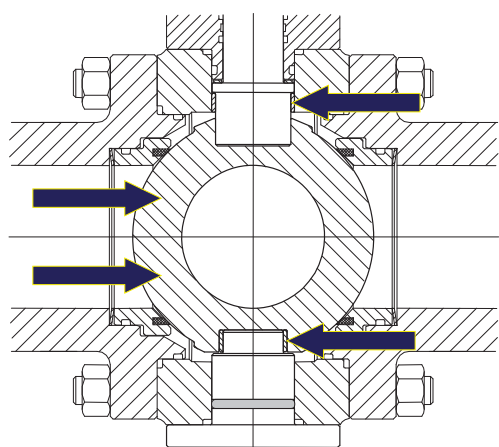

管線壓力對閥杆無至推效應

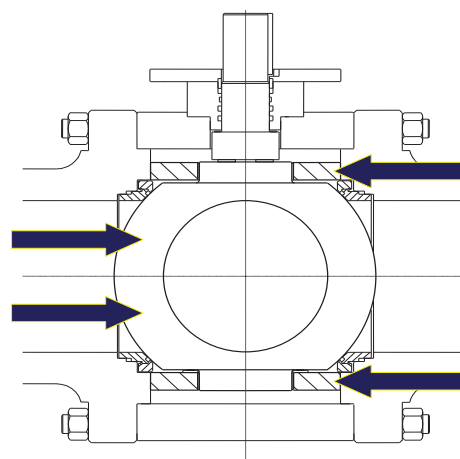

球閥的結構及原理

全焊球閥總體結構說明：

全焊接球閥採用支撐板式固定球結構，閥體採用鍛件焊接而成，閥門的重量較大。

閥杆設計成可拆卸，球體軸向載荷傳遞到閥體而不影響閥杆，使閥杆實現了純扭矩操作。

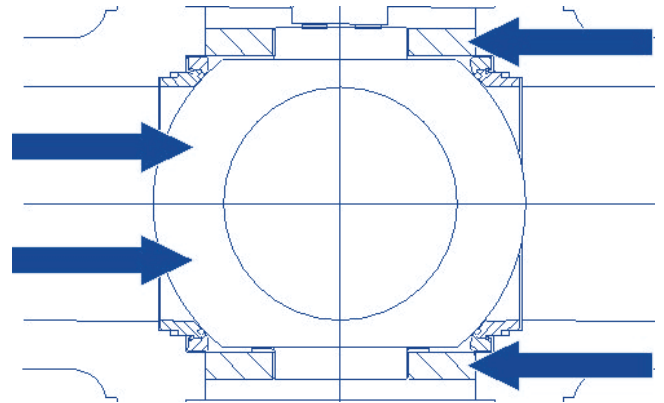
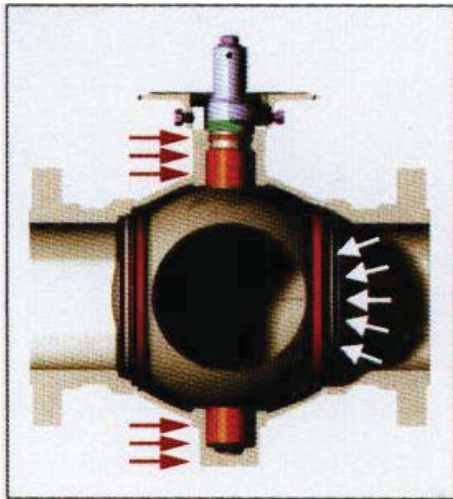

全焊接球閥閥體：閥體是採用三段式結構進行焊接，整個球閥閥體上只有兩道環焊縫。

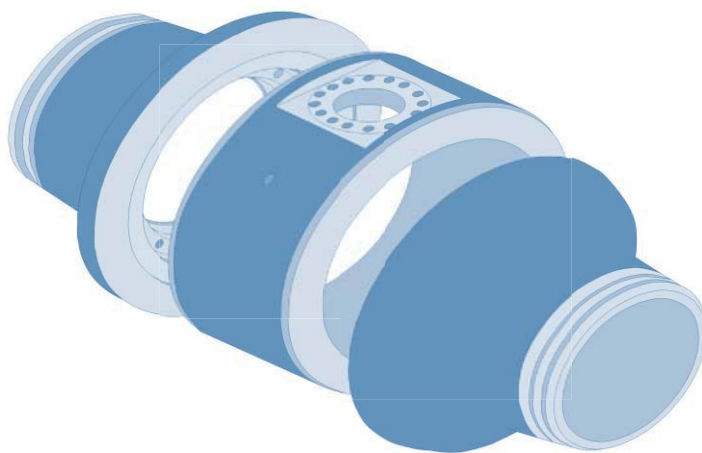

球閥的結構及原理

球體由上下支撐板固定，此結構設計閥腔內部提供了通道，將排污閥設於閥體的最底部，使排污進行的更加徹底。

上下支撐板固定支架：

- ◆ 使閥體與兩閥端從內部結構上結合為一體。
- ◆ 更有利於球閥在大口徑時閥杆克服流體的至推壓力，降低扭矩。
- ◆ 同時巧妙地留出閥底空間，將排汗閥設於閥體的最底部，利於排汗。



全焊閥閥杆：

閥杆與球體為分體結構；閥杆與球體採用扁槽與扁方形式連接；閥杆置中性優；閥杆實現純扭矩操作。

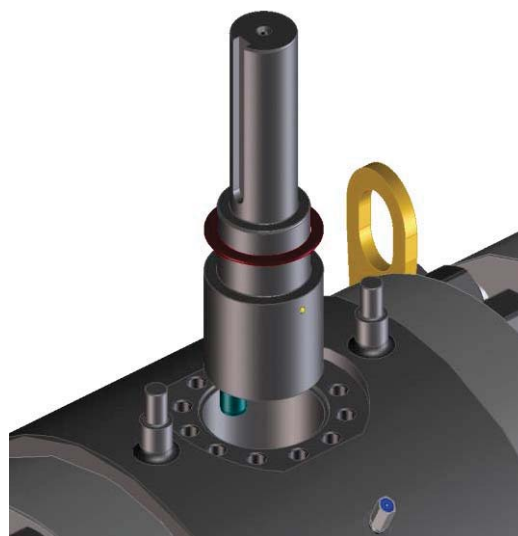

球閥的結構及原理

閥杆密封形式

“O”形圈實現雙重密封；閥杆緊急注脂密封設計；防火結構設計；防飛出結構設計；防靜電設計。

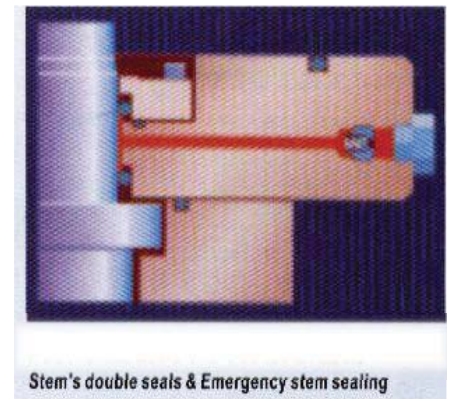
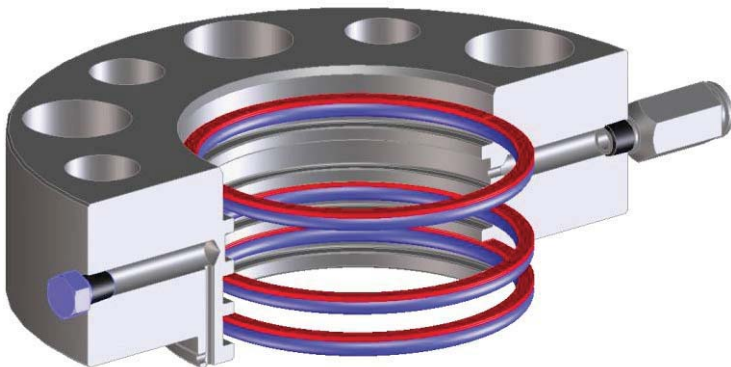

閥座結構：

球形與全焊球閥閥座結構均可設計為 **PMSS**（金屬和非金屬雙重密封）型式(硬度大於維氏硬度 **500HV**)；具有雙截斷和洩放（**DBB**）功能，中空能自行卸壓，每一側都能承受全壓差。

具有活塞效應的浮動閥座：

利用管線壓力推動浮動閥座抱球的密封形式

適應於：

高壓/大口徑/閥門扭距可以控制在允許範圍內

活塞效應閥座動作原理示圖

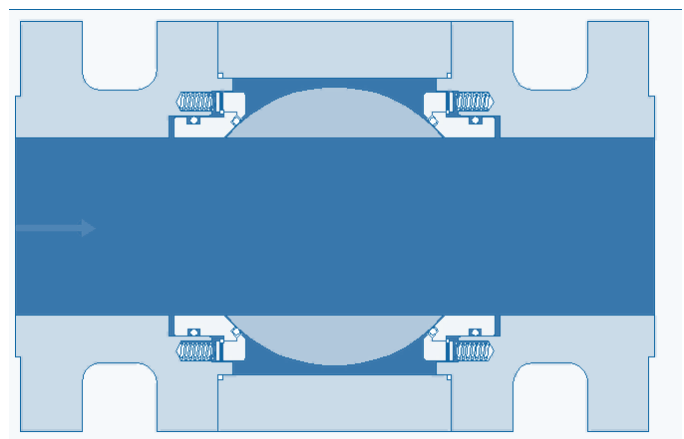
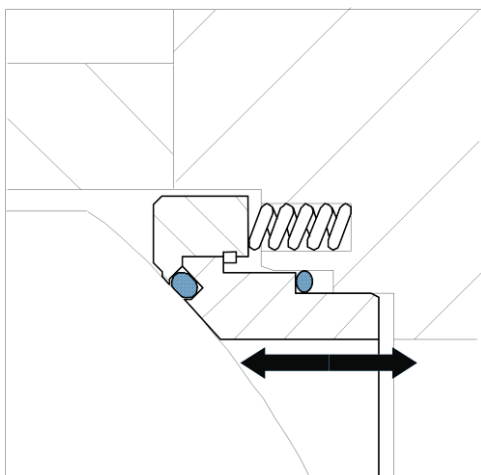

球閥的結構及原理

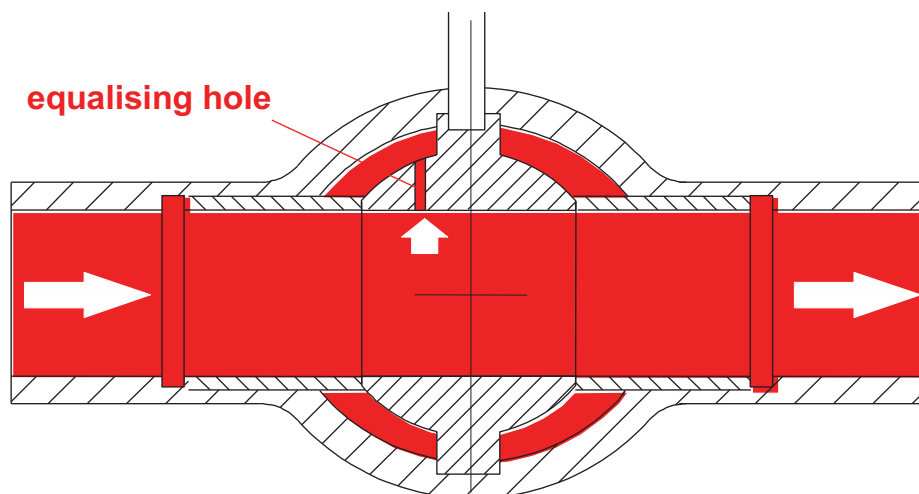

當提供壓力平衡孔時，如果是雙活塞效應閥座並且管線壓力降低，則開位閥門的閥腔壓力 P_2 無法保持。

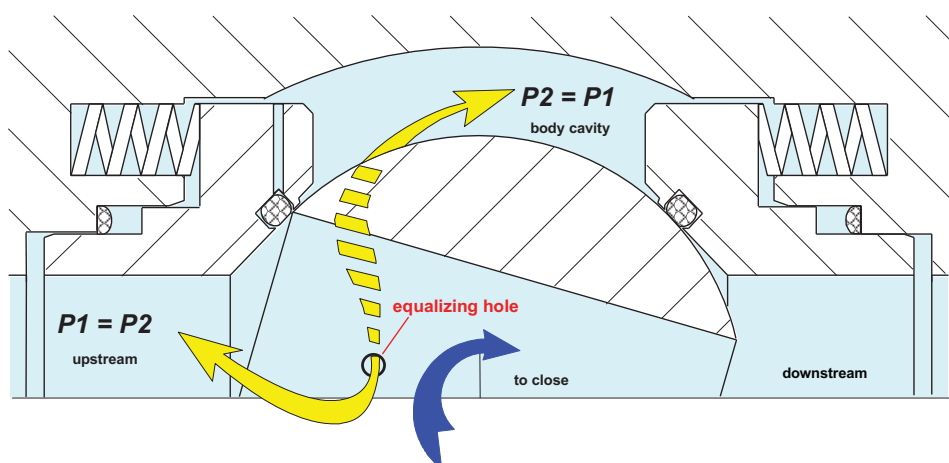

由於管線壓力 P_1 和閥腔壓力 P_2 通過壓力平衡孔達到一致，閥座內外處於完全平衡狀態，關閥啟始扭矩可以大大降低。

球閥的結構及原理

雙活塞效應的原理及特點

雙活塞效應即進口端、出口端同時密封。由於該結構沒有自動洩壓作用，處於安全考慮必須在閥體中空安裝洩壓裝置，防止閥體中空異常升壓造成閥體損壞，造成事故。因此，無論是氣體介質或液體介質，腔體必須設有安全閥，以保證壓力洩放。雙活塞效應的球閥用在對下游密封要求非常高的地方。

雙方向雙活塞效應閥座密封

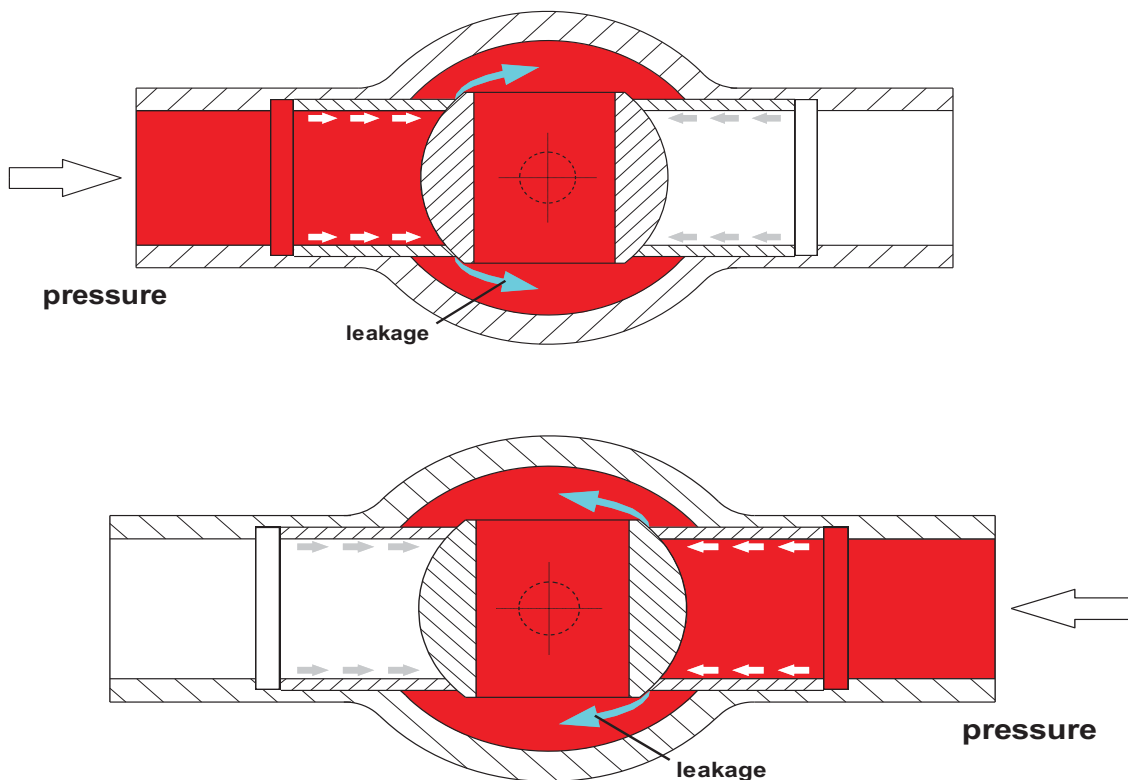

球閥的結構及原理

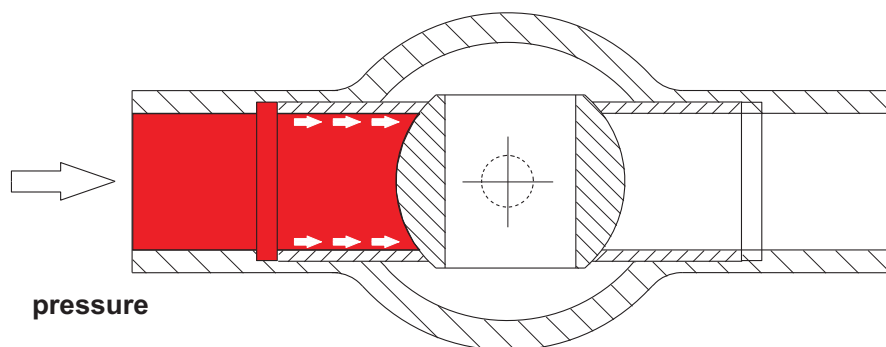

pressure

正常情況下，壓力作用於閥座密封圈的外側，這種力將迫使閥座密封圈向球體靠近擠壓，從而在閥座密封圈和球體之間形成密封。

上游閥座

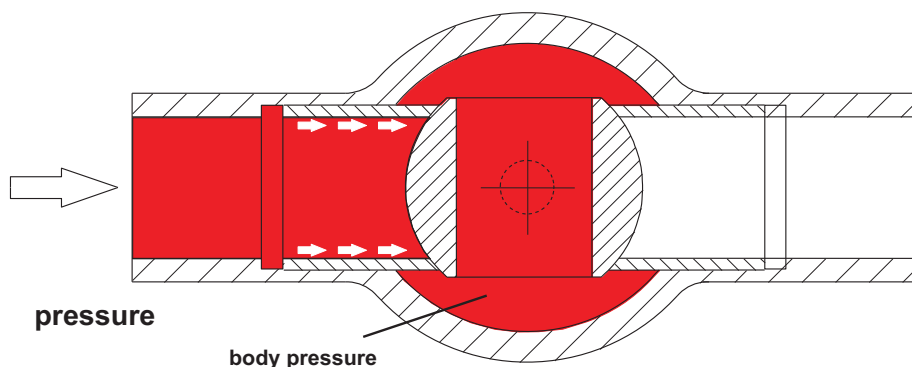
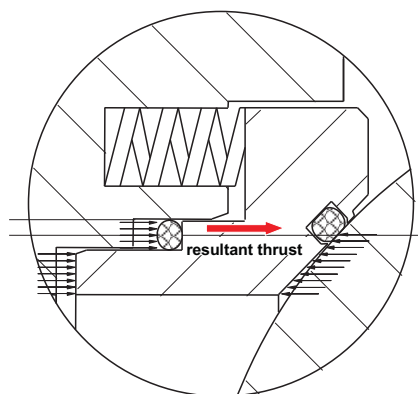

pressure

body pressure

當使用雙活塞效應閥座時，一旦上游閥座洩漏，壓力進入閥腔推動下游閥座，由於是雙活塞效應閥座設計，下游閥座會反向環抱球實現密封。

下游閥座

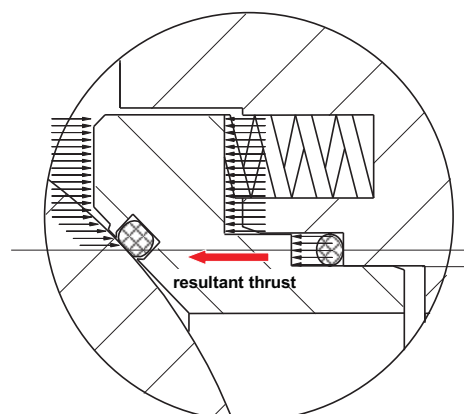

球閥的結構及原理

單活塞效應的原理及特點：

單活塞效應即進口端密封，出口端腔體壓力自動排放。該設計主要是考慮閥體的安全問題。地面上的球閥在關閉狀態下，保留在閥腔中的氣體當太陽直射閥體時將會膨脹，膨脹氣體必須被洩放。這是許多閥門使用單活塞效應，壓力自洩放設計的原因。

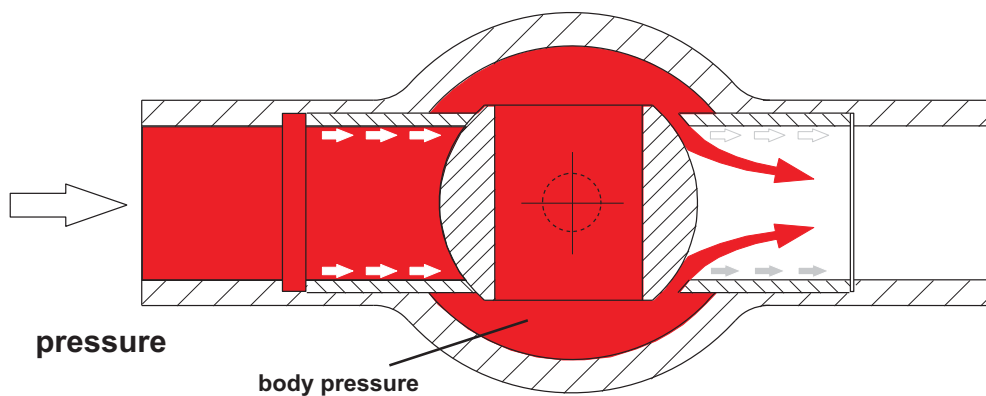

下游閥座

當使用單活塞效應閥座時，一旦上游閥座洩漏，下游閥座將脫離球體使閥腔的壓力向閥門的下游洩放。

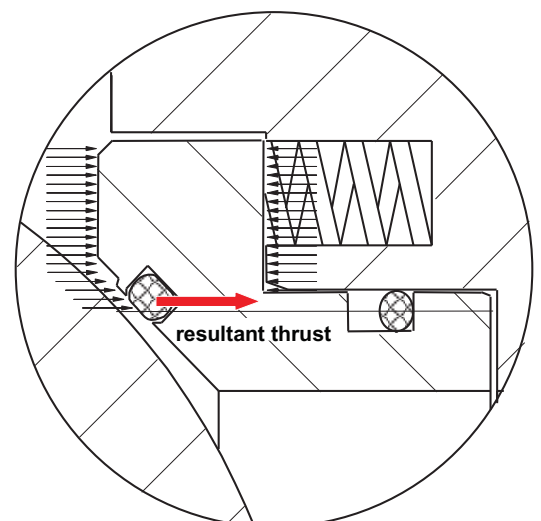

球閥的結構及原理

閥座密封脂注脂結構示意

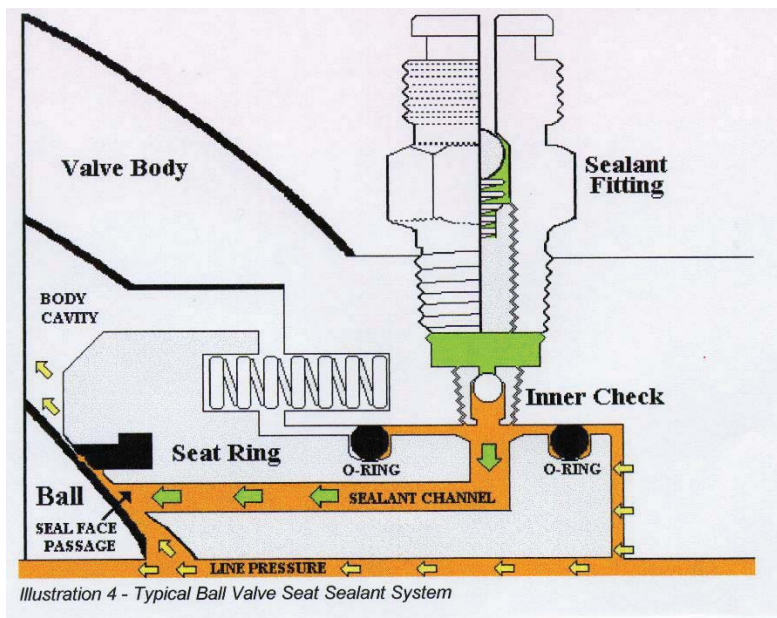

具有閥座緊急注脂系統；
有防火結構設計。

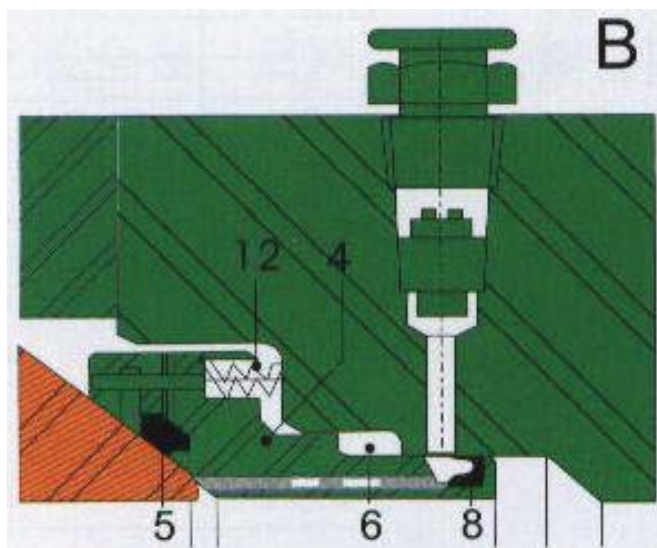

閥座密封材料：

閥座軟密封材料根據使用工況條件可選用 **PTFE**、**NEYLON**、**VITON**、**PPL** 等。

密封材料通過不同形式鑲嵌在閥座支撐上，避免使用過程中被沖出閥座支撐。

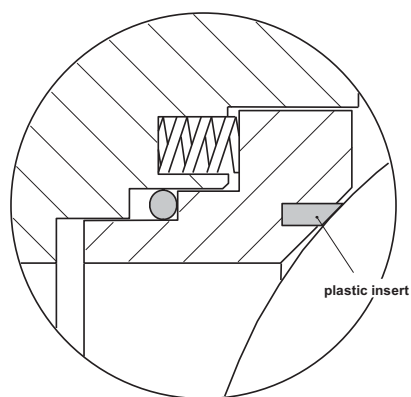

PTFE、NEYLON、PPL

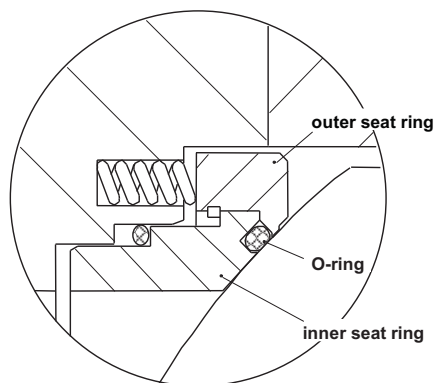

VITON

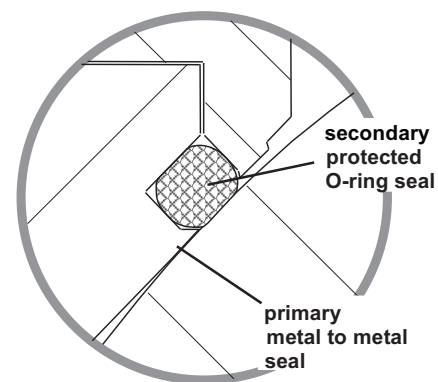

PMSS 雙重密封示意

焊接方法：全焊接球閥閥門焊接採用自動埋弧焊。



全焊接球閥典型結構

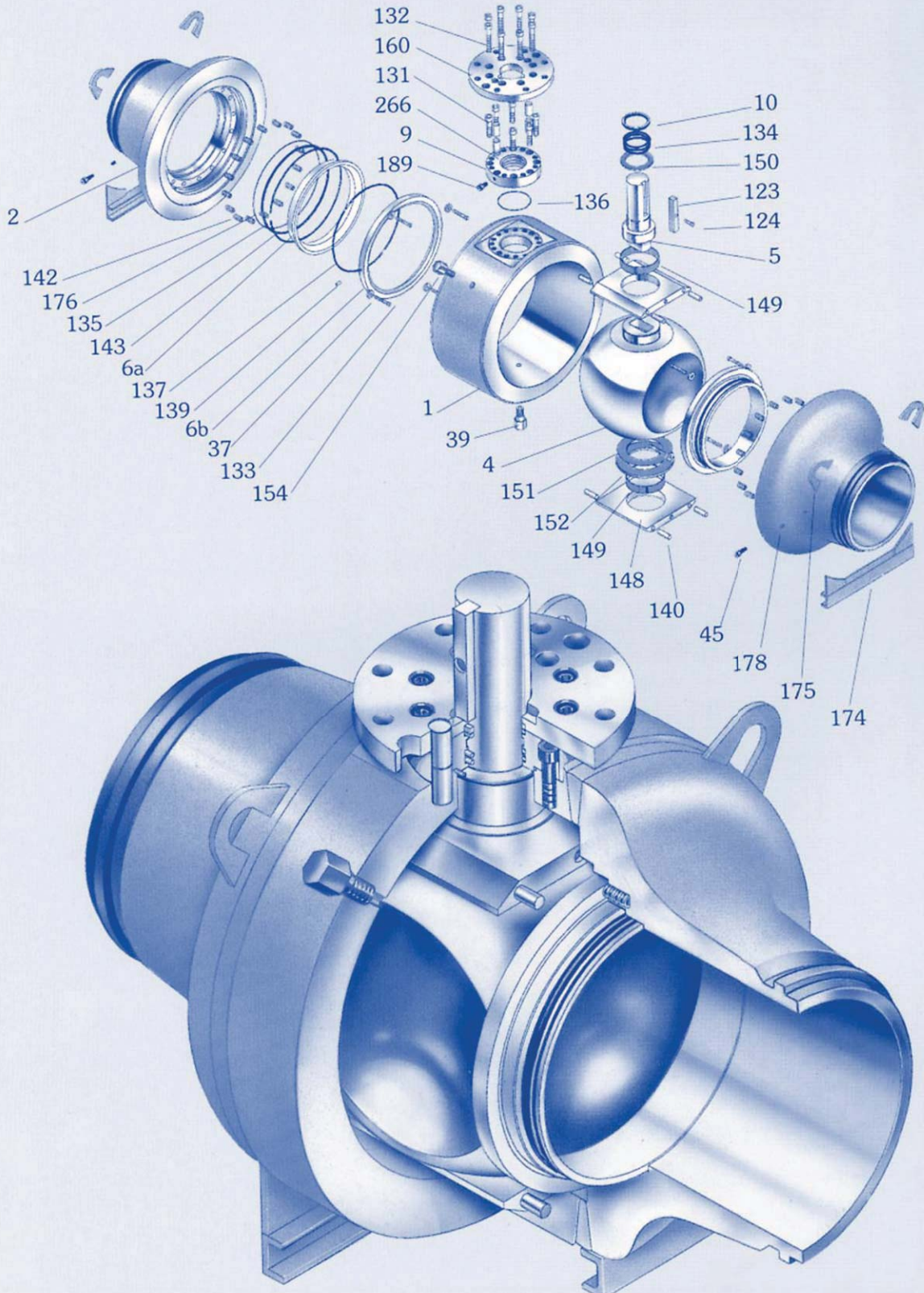

JBT-A/JBT-AM/JBT-AF/JBT-AT Trunnion Side Entry

JDV Valves Split Body Side Entry Ball Valves are manufactured in a wide range of diameters and pressure classes.

In the standard versions the valves are specified for transmission pipelines, pumping, compression and re-injection units, offshore platforms, onshore terminals, pig traps, measuring stations and surge relief skids.

In the special versions the valves are used for cryogenic service in LNG plants.

Split body construction allows the use of forged materials in various grades of carbon steel, stainless steel and high alloys thus complying with the most severe service conditions.

SIZE		ASME CLASS						
In.	mm	150	300	400	600	900	1500	2500
1 1/2	40	▲	▲	▲	▲	▲	▲	▲
2	50	▲	▲	▲	▲	▲	▲	▲
3	80	▲	▲	▲	▲	▲	▲	▲
4	100	▲	▲	▲	▲	▲	▲	▲
6	150	●	●	●	●	●	●	▲
8	200	●	●	●	●	●	●	▲
10	250	●	●	●	●	●	●	●
12	300	●	●	●	●	●	●	●
14	350	●	●	●	●	●	●	●
16	400	●	●	●	●	●	●	●
18	450	●	●	●	●	●	●	●
20	500	●	●	●	●	●	●	●
22	550	●	●	●	●	●	●	●
24	600	●	●	●	●	●	●	●
26	650	●	●	●	●	●	●	●
28	700	●	●	●	●	●	●	●
30	750	●	●	●	●	●	●	●
32	800	●	●	●	●	●	●	●
34	850	●	●	●	●	●	●	●
36	900	●	●	●	●	●	●	●
40	1000	●	●	●	●	●	●	●
42	1050	●	●	●	●	●	●	●
46	1150	●	●	●	●	●	●	●
48	1200	●	●	●	●	●	●	●
56	1400	●	●	●	●	●	●	●

B1 ▲ E1 ● For class 400LB valves are also available against specific request.
 B1: POST TRUNNION DESIGN; E1: PLATE TRUNNION DESIGN



**JDV
CONTROL
VALVES**

JBT-A/JBT-AM/JBT-AF/JBT-AT 150 Post Trunnion Ball Valve

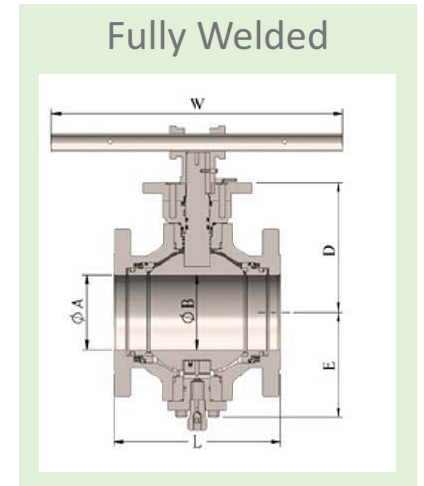
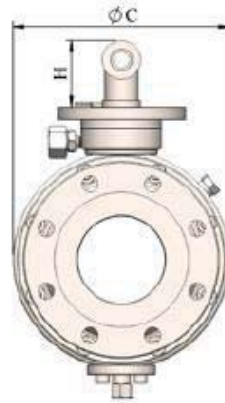
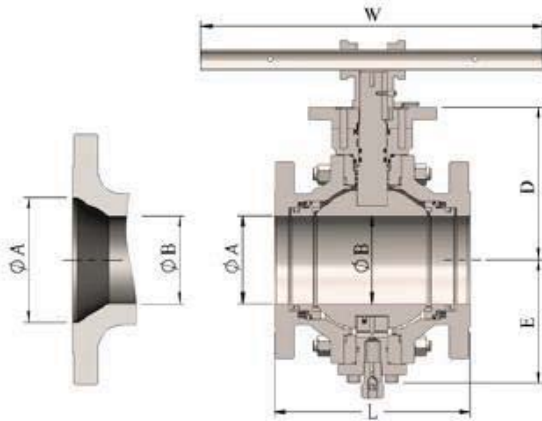

ASME CLASS 150

SIZE in/mm	A	B	L-WE	L-RF	L-RTJ	C	D	E	H	W	V	X	Y	Weight lb/kg
1 1/2	1.50	1.50	7.50	6.50	7	5.98	4.72	3.54	1.57	13.0	/	/	/	31
40	38	38	191	165	178	152	120	90	40	300	/	/	/	14
2x11/2x2	1.93	1.50	8.50	7	7.50	5.98	4.72	3.54	1.57	13.0	/	/	/	44
50x40x50	49	38	216	178	191	152	120	90	40	300	/	/	/	20
2	1.93	1.93	8.50	7	7.50	6.30	5.0	3.86	1.57	14.0	/	/	/	51
50	49	49	216	178	191	160	127	98	40	356	/	/	/	23
3x2x3	2.91	1.93	11.13	8	8.50	8.43	5.0	3.86	1.57	14.0	/	/	/	66
80x50x80	74	49	283	203	216	214	127	98	40	356	/	/	/	30
3	2.91	2.91	11.13	8	8.50	8.43	6.22	4.88	1.57	16.0	/	/	/	95
80	74	74	283	203	216	214	158	124	40	406	/	/	/	43
4x3x4	3.94	2.91	12	9.02	9.50	10.0	6.22	4.88	1.57	16.0	/	/	/	123
100x80x100	100	74	305	229	241	254	158	124	40	406	/	/	/	56
4	3.94	3.94	12	9.02	9.50	10.0	7.0	5.67	1.57	18.1	/	/	/	161
100	100	100	305	229	241	254	178	144	40	560	/	/	/	73
6x4x6	5.91	3.94	18	15.50	16.00	10.94	7.0	5.67	1.57	18.1	/	/	/	170
150x100x150	150	100	457	394	406	279	178	144	40	560	/	/	/	77

Note: (*) Upon Request. For dimensions & weights in larger sizes consult the factory.
Dimensions C, D, E, H, V, X, Y and weights are subject to change without notice.

JBT-A/JBT-AM/JBT-AF/JBT-AT 300 Post Trunnion Ball Valve

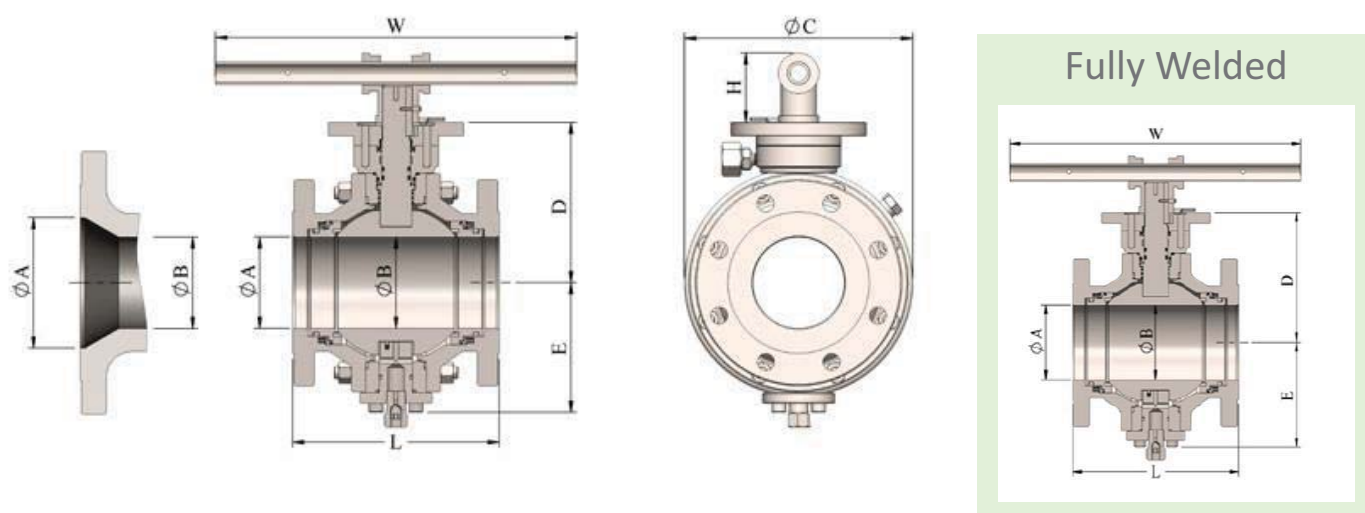

ASME CLASS 300

SIZE in/mm	A	B	L-WE	L-RF	L-RTJ	C	D	E	H	W	V	X	Y	Weight lb/kg
1 1/2	1.50	1.50	7.50	7.50	8	6.30	4.72	3.54	1.57	15	/	/	/	40
40	38	38	191	191	203	160	120	90	40	382	/	/	/	18
2x1 1/2x2	1.93	1.50	8.50	8.50	9.13	6.50	4.72	3.54	1.57	15	/	/	/	55
50x40x50	49	38	216	216	232	165	120	90	40	382	/	/	/	25
2	1.93	1.93	8.50	8.50	9.13	6.50	5.0	3.86	1.57	17	/	/	/	59
50	49	49	216	216	232	165	127	98	40	432	/	/	/	27
3x2x3	2.91	1.93	11.13	11.13	11.75	7.52	5.0	3.86	1.57	17	/	/	/	75
80x50x80	74	49	283	283	298	191	127	98	40	432	/	/	/	34
3	2.91	2.91	11.13	11.13	11.75	8.66	6.22	4.88	1.57	22.2	/	/	/	119
80	74	74	283	283	298	220	158	124	40	560	/	/	/	54
4x3x4	3.94	2.91	12	12	12.63	9.02	6.22	4.88	1.57	22.2	/	/	/	132
100x80x100	100	74	305	305	321	229	158	124	40	560	/	/	/	60
4	3.94	3.94	12	12	12.63	10.0	7.0	5.67	1.57	24	/	/	/	196
100	100	100	305	305	321	254	178	144	40	700	/	/	/	89
6x4x6	5.91	3.94	18	15.88	16.5	12.52	7.0	5.67	1.57	24	/	/	/	223
150x100x150	150	100	457	403	419	318	178	144	40	700	/	/	/	101



**JDV
CONTROL
VALVES**

JBT-A/JBT-AM/JBT-AF/JBT-AT 600# Post Trunnion (B1) Ball Valve

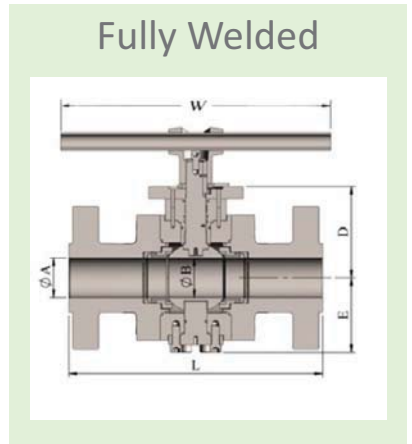
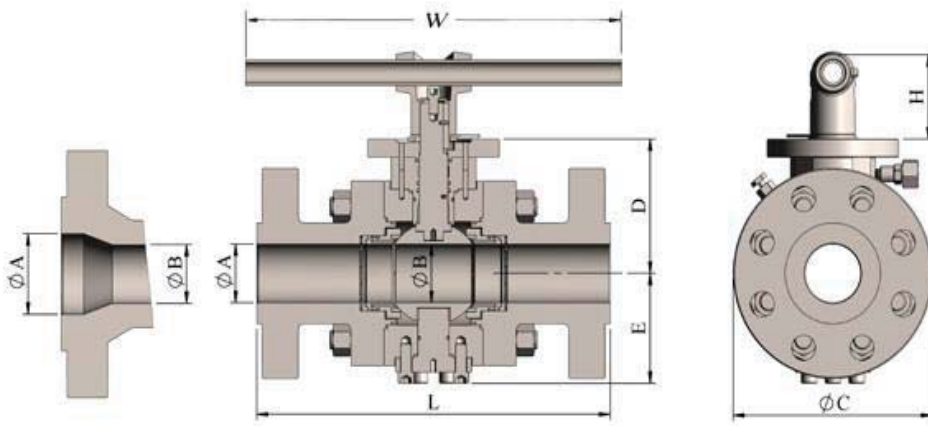

ASME CLASS 600

SIZE in/mm	A	B	L-WE	L-RF	L-RTJ	C	D	E	H	W	V	X	Y	Weight lb/kg
1 1/2	1.50	1.50	9.50	9.50	9.50	6.50	5.79	4.33	1.57	19.0	/	/	/	46
40	38	38	241	241	241	165	147	110	40	482	/	/	/	21
2x11/2x2	1.93	1.50	11.5	11.5	11.63	6.69	5.79	4.33	1.57	19.0	/	/	/	55
50x40x50	49	38	292	292	295	170	147	110	40	482	/	/	/	25
2	1.93	1.93	11.5	11.5	11.63	6.69	5.91	4.33	1.57	23.0	/	/	/	62
50	49	49	292	292	295	170	150	110	40	584	/	/	/	28
3x2x3	2.91	1.93	14.0	14.0	14.13	8.66	5.91	4.33	1.57	23.0	/	/	/	86
80x50x80	74	49	356	356	359	220	150	110	40	584	/	/	/	39
3	2.91	2.91	14.0	14.0	14.13	8.66	6.81	5.20	2.17	28.0	/	/	/	130
80	74	74	356	356	359	220	173	132	55	712	/	/	/	59
4x3x4	3.94	2.91	17	17	17.13	10.39	6.81	5.20	2.17	28.0	/	/	/	168
100x80x100	100	74	432	432	435	264	173	132	55	712	/	/	/	76
4	3.94	3.94	17	17	17.13	10.39	7.72	6.30	2.17	34.0	16.0	2.17	10.0	249
100	100	100	432	432	435	264	196	160	55	864	406	55	254	113
6x4x6	5.91	3.94	22.0	22.0	22.13	14.0	7.72	6.30	2.17	34.0	16.0	2.17	10.0	335
150x100x150	150	100	559	559	562	356	196	160	55	864	406	55	254	152

Note: (*) Upon Request. For dimensions & weights in larger sizes consult the factory.
Dimensions C, D, E, H, V, X, Y and weights are subject to change without notice.

JBT-A/JBT-AM/JBT-AF/JBT-AT 900# Post Trunnion (B1) Ball Valve

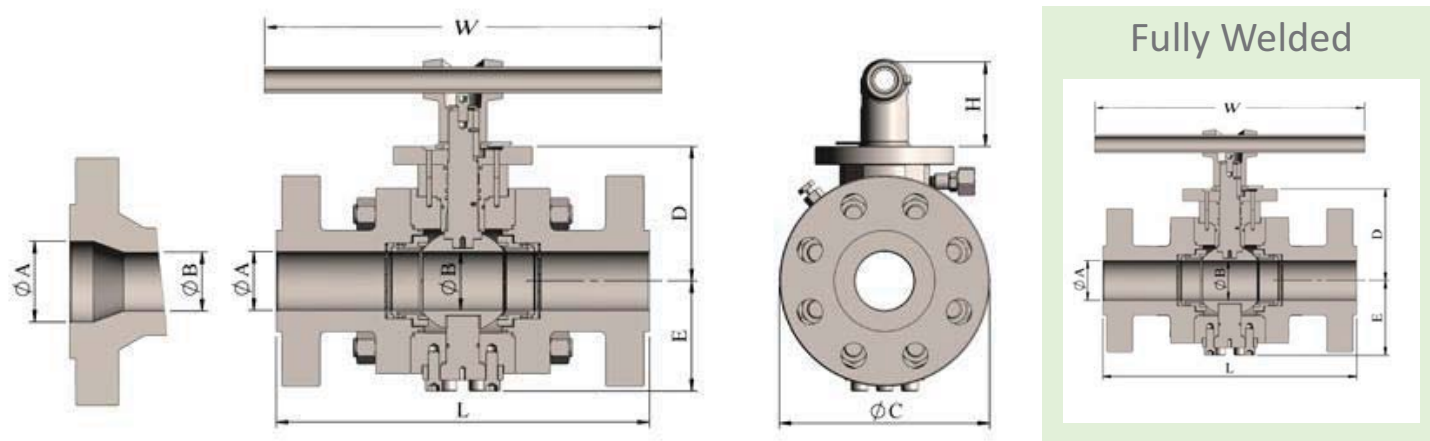

ASME CLASS 900

SIZE in/mm	A	B	L-WE	L-RF	L-RTJ	C	D	E	H	W	V	X	Y	Weight lb/kg
1 1/2	1.50	1.50	12.0	12.0	12.0	6.50	5.79	4.33	1.57	24.0	/	/	/	68
40	38	38	305	305	305	165	147	110	40	610	/	/	/	31
2x11/2x2	1.93	1.50	14.49	14.49	14.61	8.50	5.79	4.33	1.57	24.0	/	/	/	95
50x40x50	49	38	368	368	371	216	147	110	40	610	/	/	/	43
2	1.93	1.93	14.49	14.49	14.61	8.50	6.06	4.41	1.57	29.0	/	/	/	130
50	49	49	368	368	371	216	154	112	40	736	/	/	/	59
3x2x3	2.91	1.93	15.0	15.0	15.12	9.49	6.06	4.41	1.57	29.0	/	/	/	143
80x50x80	74	49	381	381	384	241	154	112	40	736	/	/	/	65
3	2.91	2.91	15.0	15.0	15.12	9.49	7.17	5.59	2.17	30.0	/	/	/	187
80	74	74	381	381	384	241	182	142	55	762	/	/	/	85
4x3x4	3.94	2.91	18.0	18.0	18.11	11.5	7.17	5.59	2.17	30.0	/	/	/	240
100x80x100	100	74	457	457	460	292	182	142	55	762	/	/	/	109
4	3.94	3.94	18.0	18.0	18.11	11.5	8.07	6.69	2.17	36.0	16.0	2.17	10.0	390
100	100	100	457	457	460	292	205	170	55	914	406	55	254	177
6x4x6	5.91	3.94	24.02	24.02	24.13	15.0	8.07	6.69	2.17	36.0	16.0	2.17	10.0	489
150x100x150	150	100	610	610	613	381	205	170	55	914	406	55	254	222



**JDV
CONTROL
VALVES**

JBT-A/JBT-AM/JBT-AF/JBT-AT 1500# Post Trunnion (B1) Ball Valve

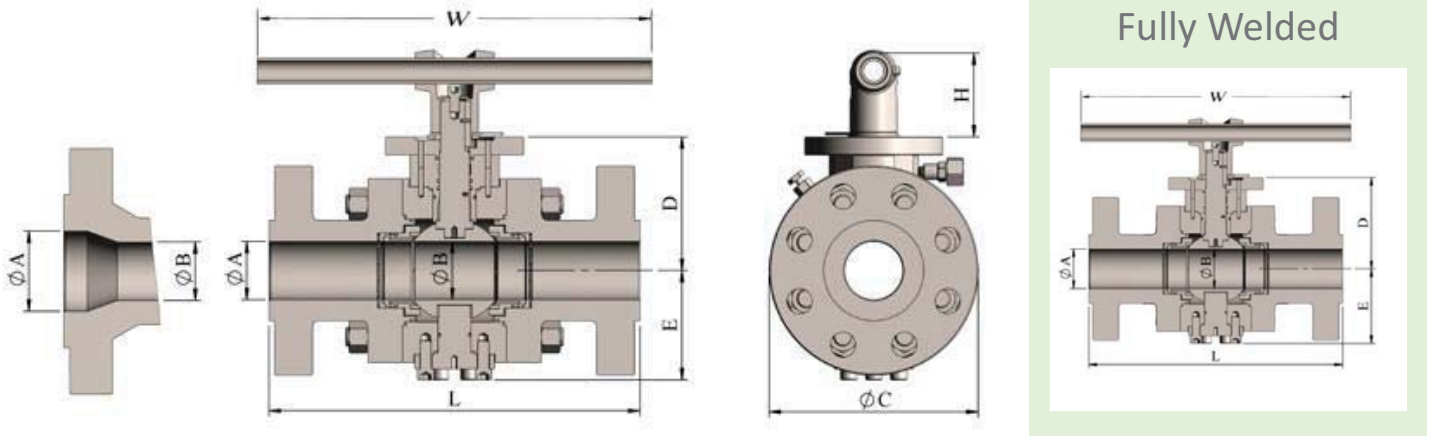

ASME CLASS 1500

SIZE in/mm	A	B	L-WE	L-RF	L-RTJ	C	D	E	H	W	V	X	Y	Weight lb/kg
1 1/2 40	1.50 38	1.50 38	12.0 305	12.0 305	12.0 305	6.50 165	5.79 147	4.33 110	1.57 40	24 710	/	/	/	68 31
2x1 1/2x2 50x40x50	1.93 49	1.50 38	14.49 368	14.49 368	14.61 371	8.50 216	5.79 147	4.33 110	1.57 40	24 710	/	/	/	95 43
2 50	1.93 49	1.93 49	14.49 368	14.49 368	14.61 371	8.50 216	6.06 154	4.41 112	1.57 40	29.0 736	/	/	/	130 59
3x2x3 80x50x80	2.91 74	1.93 49	18.5 470	18.5 470	18.62 473	10.43 265	6.06 154	4.41 112	1.57 40	29.0 736	/	/	/	168 76
3 80	2.91 74	2.91 74	18.5 470	18.5 470	18.62 473	10.43 265	7.87 200	6.38 162	2.17 55	37.0 946	/	/	/	240 109
4x3x4 100x80x100	3.94 100	2.91 74	21.5 546	21.5 546	21.61 549	12.24 311	7.87 200	6.38 162	2.17 55	37.0 946	/	/	/	311 141
4 100	3.94 100	3.94 100	21.5 546	21.5 546	21.61 549	12.24 311	8.50 216	7.48 190	2.17 55	43.0 1092	16.0 406	2.17 55	10.0 254	399 181
6x4x6 150x100x150	5.67 144	3.94 100	27.76 705	27.76 705	27.99 711	15.55 395	8.50 216	7.48 190	2.17 55	43.0 1092	16.0 406	2.17 55	10.0 254	628 285

Note: (*) Upon Request. For dimensions & weights in larger sizes consult the factory.
Dimensions C, D, E, H, V, X, Y and weights are subject to change without notice.

JBT-A/JBT-AM/JBT-AF/JBT-AT 2500# Post Trunnion (B1) Ball Valve

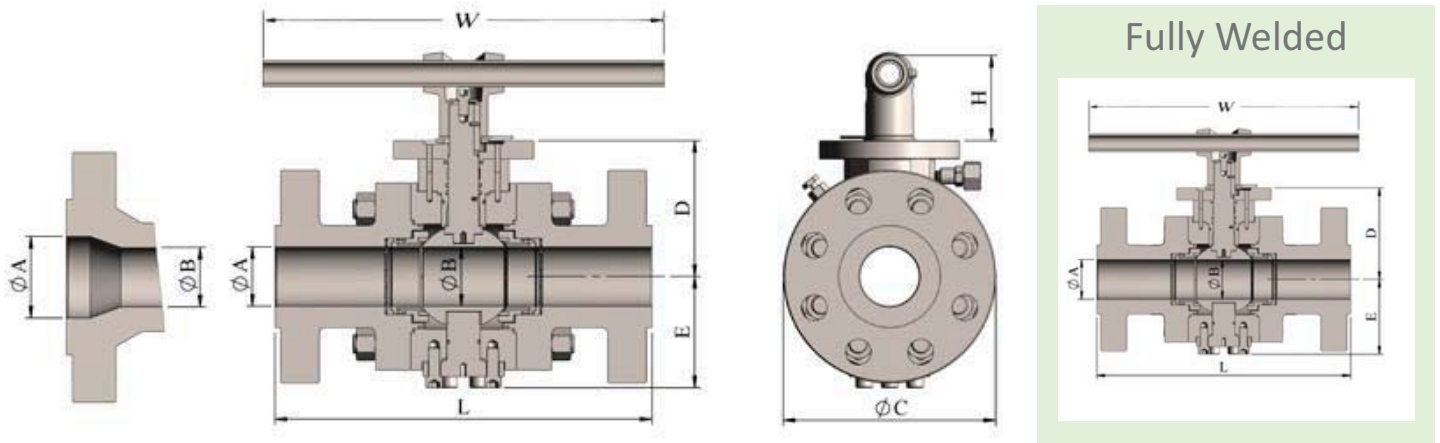

ASME CLASS 2500

SIZE in/mm	A	B	L-WE	L-RF	L-RTJ	C	D	E	H	W	V	X	Y	Weight lb/kg
1 1/2 40	1.50 38	1.50 38	14.49 368	14.49 368	14.61 371	8.07 205	6.26 159	4.72 120	1.57 40	29.0 736	/	/		130 59
2x11/2x2 50x40x50	1.65 42	1.50 38	17.76 451	17.76 451	17.87 451	9.25 235	6.26 159	4.72 120	1.57 40	29.0 736	/	/		143 65
2 50	1.65 42	1.65 42	17.76 451	17.76 451	17.87 451	9.25 235	6.54 166	5.12 130	2.17 55	35.5 902	16.0 406	/	/	194 88
3x2x3 80x50x80	2.44 62	1.65 42	22.76 578	22.76 578	22.99 584	12.01 305	6.54 166	5.12 130	2.17 55	35.5 902	16.0 406	/	/	341 155
3 80	2.44 62	2.44 62	22.76 578	22.76 578	22.99 584	12.01 305	8.39 213	7.01 178	2.36 60	45.5 1156	16.0 406	/	/	411 187
4x3x4 100x80x100	3.43 87	2.44 62	26.5 673	26.5 673	26.89 683	16.34 415	8.39 213	7.01 178	2.36 60	45.5 1156	16.0 406	/	/	581 264
4 100	3.43 87	3.43 87	26.5 673	26.5 673	26.89 683	16.34 415	11.10 282	10.08 256	3.15 80	n/a	20.0 508	3.15 80	12.0 305	836 380
6x4x6 150x100x150	5.16 131	3.43 87	35.98 914	35.98 914	36.5 927	19.09 485	11.10 282	10.08 256	3.15 80	n/a	20.0 508	3.15 80	12.0 305	1122 510



**JDV
CONTROL
VALVES**

JBT-A/JBT-AM/JBT-AF/JBT-AT 150 Plate Trunnion Ball Valve

ASME CLASS 150 E1 Series

SIZE in/mm	A	B	L-WE	L-RF	L-RTJ	C	D	E	H	W	V	X	Y	Weight lb/kg
6	5.91	5.91	18	15.50	16.00	12.44	8.27	8.58	2.36	31.0	16.0	2.36	8.75	391
150	150	150	457	394	406	316	210	218	60	788	406	60	292	177
8	7.91	7.91	20.5	18	18.5	15.08	9.45	10.08	2.56	36.0	16.0	2.56	8.75	560
200	201	201	521	457	470	383	240	256	65	914	406	65	292	254
10	9.92	9.92	22	21	21.5	18.90	11.57	11.65	3.15	n/a	20.0	3.15	8.75	927
250	252	252	559	533	546	480	294	296	80	n/a	508	80	292	420
12	11.93	11.93	25	24	24.5	22.44	13.78	14.37	3.54	n/a	24.0	3.54	16.5	1450
300	303	303	635	610	622	570	350	365	90	n/a	610	90	419	658
14	13.15	13.15	30	27	27.5	24.61	14.88	15.43	3.94	n/a	24.0	3.94	16.5	1800
350	334	334	762	686	699	625	378	392	100	n/a	610	100	419	816
16	15.16	15.16	33	30	30.5	27.95	16.73	17.13	4.72	n/a	28.0	4.72	16.5	2570
400	385	385	838	762	775	710	425	435	120	n/a	711	120	419	1166
18	17.17	17.17	36	34	34.5	30.12	17.91	18.31	4.72	n/a	28.0	4.72	16.5	3020
450	436	436	914	864	876	765	455	465	120	n/a	711	120	419	1370
20	19.17	19.17	39	36	36.5	32.87	19.88	23.11	4.72	n/a	28.0	4.72	22.0	4050
500	487	487	991	914	927	835	505	587	120	n/a	711	120	559	1837
22	21.18	21.18	(*)	(*)	(*)	36.26	21.14	24.80	4.72	n/a	28.0	4.72	22.0	5020
550	538	538	(*)	(*)	(*)	921	537	630	120	n/a	711	120	559	2277
24	23.19	23.19	45	42	42.5	38.90	22.52	26.38	7.09	n/a	28.0	7.09	22.0	6818
600	589	589	1143	1067	1080	988	572	670	180	n/a	711	180	559	3099
26	24.92	24.92	49	45	(*)	41.73	24.49	28.27	7.09	n/a	28.0	7.09	22.0	8107
650	633	633	1245	1143	(*)	1060	622	718	180	n/a	711	180	559	3685
28	26.93	26.93	53	49	(*)	44.76	25.87	29.65	7.09	n/a	30.0	7.09	23.5	9878
700	684	684	1346	1245	(*)	1137	657	753	180	n/a	762	180	597	4490

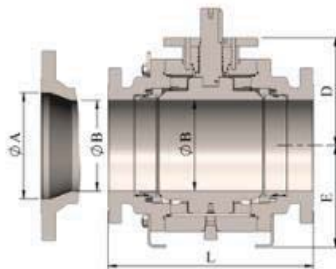
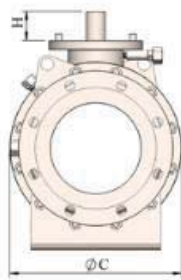
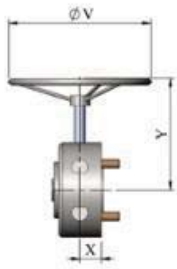

Fully Welded

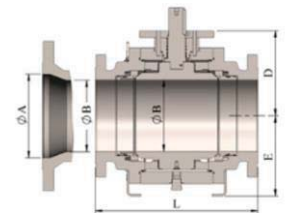
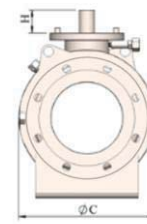

ASME CLASS 150 E1 Series

SIZE in/mm	A	B	L-WE	L-RF	L-RTJ	C	D	E	H	W	V	X	Y	Weight lb/kg
30	28.94	28.94	55	51	(*)	49.02	27.52	31.73	8.07	n/a	30.0	8.07	23.5	11473
750	735	735	1397	1295	(*)	1245	699	806	205	n/a	762	205	597	5215
32	30.67	30.67	60	54	(*)	50.98	29.02	33.27	8.07	n/a	30.0	8.07	23.5	14960
800	779	779	1524	1372	(*)	1295	737	845	205	n/a	762	205	597	6800
34	32.68	32.68	64	58	(*)	53.39	30.87	34.37	8.07	n/a	30.0	8.07	23.5	17160
850	830	830	1626	1473	(*)	1356	784	873	205	n/a	762	205	597	7800
36	34.41	34.41	68	60	(*)	56.73	32.36	35.75	8.07	n/a	30.0	8.07	23.5	19360
900	874	874	1727	1524	(*)	1441	822	908	205	n/a	762	205	597	8800
40	38.43	38.43	(*)	(*)	(*)	63.90	35.63	39.37	8.07	n/a	32.0	8.07	23.5	27632
1000	976	976	(*)	(*)	(*)	1623	905	1000	205	n/a	812	205	597	12560
42	40.16	40.16	(*)	(*)	(*)	69.72	38.11	40.75	8.07	n/a	32.0	8.07	23.5	31416
1050	1020	1020	(*)	(*)	(*)	1771	968	1035	205	n/a	812	205	597	14280
48	45.91	45.91	(*)	(*)	(*)	77.52	44.37	46.38	8.07	n/a	32.0	8.07	25.0	48180
1200	1166	1166	(*)	(*)	(*)	1969	1127	1178	205	n/a	812	205	635	21900
54	51.65	51.65	(*)	(*)	(*)	84.61	46.73	47.87	9.65	n/a	32.0	9.65	25.0	68565
1350	1312	1312	(*)	(*)	(*)	2149	1187	1216	245	n/a	812	245	635	31060
56	57.40	57.40	(*)	(*)	(*)	89.76	50.39	52.01	9.65	n/a	32.0	9.65	25.0	75275
1400	1458	1458	(*)	(*)	(*)	2280	1280	1321	245	n/a	812	245	635	34100

Note: (*) Upon Request. For dimensions & weights in larger sizes consult the factory. Dimensions C, D, E, H, V, X, Y and weights are subject to change without notice.

JBT-A/JBT-AM/JBT-AF/JBT-AT 300 Plate Trunnion Ball Valve

ASME CLASS 300 E1 Series

SIZE in/mm	A	B	L-WE	L-RF	L-RTJ	C	D	E	H	W	V	X	Y	Weight lb/kg
6	5.91	5.91	18	15.9	16.5	12.44	8.27	8.58	2.36	31.8	16.0	2.36	8.75	408
150	150	150	457	403	419	316	210	218	60	806	406	60	292	185
8	7.91	7.91	20.5	19.8	20.4	15.08	9.45	10.08	2.56	39.6	16.0	2.56	8.75	622
200	201	201	521	502	518	383	240	256	65	1004	406	65	292	282
10	9.92	9.92	22	22.4	23	18.90	11.57	11.65	3.15	n/a	20.0	3.15	8.75	1100
250	252	252	559	568	584	480	294	296	80	n/a	508	80	292	500
12	11.93	11.93	25	25.5	26.1	22.44	13.78	14.37	3.54	n/a	24.0	3.54	16.5	1613
300	303	303	635	648	664	570	350	365	90	n/a	610	90	419	733
14	13.15	13.15	30	30	30.6	24.61	14.88	15.43	3.94	n/a	24.0	3.94	16.5	2264
350	334	334	762	762	778	625	378	392	100	n/a	610	100	419	1029
16	15.16	15.16	33	33	33.6	27.95	16.73	17.13	4.72	n/a	28.0	4.72	16.5	3120
400	385	385	838	838	854	710	425	435	120	n/a	711	120	419	1418
18	17.17	17.17	36	36	36.6	30.12	17.91	18.31	4.72	n/a	28.0	4.72	16.5	3502
450	436	436	914	914	930	765	455	465	120	n/a	711	120	419	1592
20	19.17	19.17	39	39	39.8	33.27	19.88	23.11	4.72	n/a	28.0	4.72	22.0	4829
500	487	487	991	991	1010	845	505	587	120	n/a	711	120	559	2195
22	21.18	21.18	43	43	43.9	36.61	21.14	24.80	4.72	n/a	28.0	4.72	22.0	6134
550	538	538	1092	1092	1114	930	537	630	120	n/a	711	120	559	2788
24	23.19	23.19	45	45	45.9	39.25	22.52	26.38	7.09	n/a	28.0	7.09	22.0	7612
600	589	589	1143	1143	1165	997	572	670	180	n/a	711	180	559	3460
26	24.92	24.92	49	49	50	42.13	24.49	28.27	7.09	n/a	28.0	7.09	22.0	10252
650	633	633	1245	1245	1270	1070	622	718	180	n/a	711	180	559	4660
28	26.93	26.93	53	53	54	45.24	25.87	29.65	7.09	n/a	30.0	7.09	23.5	12694
700	684	684	1346	1346	1372	1149	657	753	180	n/a	762	180	597	5770

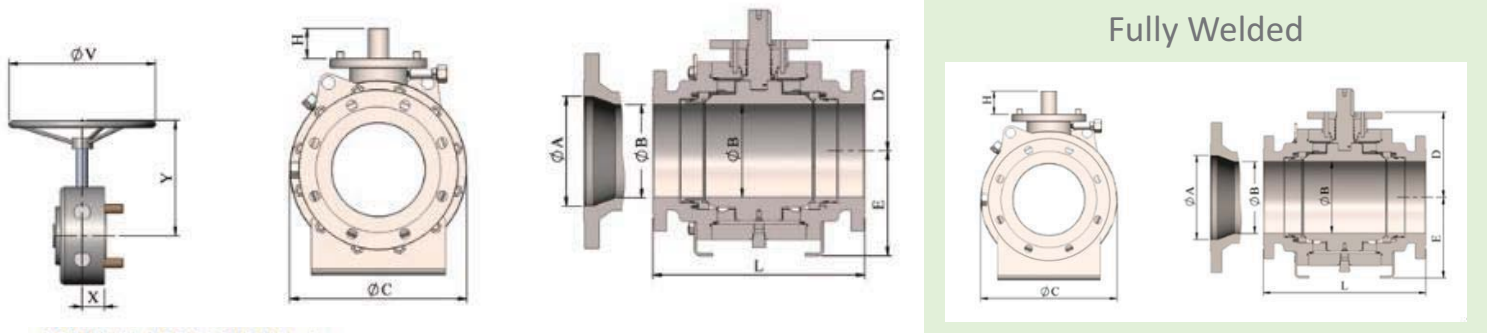

ASME CLASS 300 E1 Series

SIZE in/mm	A	B	L-WE	L-RF	L-RTJ	C	D	E	H	W	V	X	Y	Weight lb/kg
30	28.94	28.94	55	55	56	49.13	27.52	31.73	8.07	n/a	30.0	8.07	23.5	14498
750	735	735	1397	1397	1422	1248	699	806	205	n/a	762	205	597	6590
32	30.67	30.67	60	60	61.1	51.50	29.02	33.27	8.07	n/a	30.0	8.07	23.5	17450
800	779	779	1524	1524	1553	1308	737	845	205	n/a	762	205	597	7932
34	32.68	32.68	64	64	65.1	53.90	30.87	34.37	8.07	n/a	30.0	8.07	23.5	19888
850	830	830	1626	1626	1654	1369	784	873	205	n/a	762	205	597	9040
36	34.41	34.41	68	68	69.1	57.36	32.36	35.75	8.07	n/a	30.0	8.07	23.5	22205
900	874	874	1727	1727	1756	1457	822	908	205	n/a	762	205	597	10093
40	38.43	38.43	(*)	(*)	(*)	64.49	35.63	39.37	8.07	n/a	32.0	8.07	23.5	30305
1000	976	976	(*)	(*)	(*)	1638	905	1000	205	n/a	812	205	597	13775
42	40.16	40.16	(*)	(*)	(*)	72.05	38.11	40.75	8.07	n/a	32.0	8.07	23.5	35431
1050	1020	1020	(*)	(*)	(*)	1830	968	1035	205	n/a	812	205	597	16105
48	45.91	45.91	(*)	(*)	(*)	78.27	44.37	46.38	8.07	n/a	32.0	8.07	25.0	52932
1200	1166	1166	(*)	(*)	(*)	1988	1127	1178	205	n/a	812	205	635	24060
54	51.65	51.65	(*)	(*)	(*)	86.42	46.73	47.87	9.65	n/a	32.0	9.65	25.0	75403
1350	1312	1312	(*)	(*)	(*)	2195	1187	1216	245	n/a	812	245	635	34158
56	57.40	57.40	(*)	(*)	(*)	90.75	50.39	52.01	9.65	n/a	32.0	9.65	25.0	83941
1400	1458	1458	(*)	(*)	(*)	2305	1280	1321	245	n/a	812	245	635	38155

Note: (*) Upon Request. For dimensions & weights in larger sizes consult the factory. Dimensions C, D, E, H, V, X, Y and weights are subject to change without notice.



**JDV
CONTROL
VALVES**

JBT-A/JBT-AM/JBT-AF/JBT-AT 600 Plate Trunnion Ball Valve

ASME CLASS 600 E1 Series

SIZE in/mm	A	B	L-WE	L-RF	L-RTJ	C	D	E	H	W	V	X	Y	Weight lb/kg
6	5.91	5.91	22	22	22.13	14.02	9.13	8.66	2.56	44.0	16.0	2.56	8.75	563
150	150	150	559	559	562	356	232	220	65	1118	406	65	292	255
8	7.91	7.91	26	26	26.13	16.73	10.83	10.63	2.56	n/a	20.0	2.56	8.75	984
200	201	201	660	660	664	425	275	270	65	n/a	508	65	292	446
10	9.92	9.92	31	31	31.13	20.00	12.91	12.40	3.54	n/a	20.0	3.54	8.75	1630
250	252	252	787	787	790	508	328	315	90	n/a	508	90	292	739
12	11.93	11.93	33	33	33.13	23.78	14.49	15.20	3.94	n/a	24.0	3.94	16.5	2270
300	303	303	838	838	841	604	368	386	100	n/a	610	100	419	1030
14	13.15	13.15	35	35	35.12	25.20	15.24	14.80	3.94	n/a	24.0	3.94	16.5	2790
350	334	334	889	889	892	640	387	376	100	n/a	610	100	419	1266
16	15.16	15.16	39	39	39.12	29.13	17.32	17.52	4.53	n/a	28.0	4.53	16.5	3350
400	385	385	991	991	994	740	440	445	115	n/a	711	115	419	1520
18	17.17	17.17	43	43	43.12	30.98	18.70	18.70	5.51	n/a	28.0	5.51	16.5	4690
450	436	436	1092	1092	1095	787	475	475	140	n/a	711	140	419	2127
20	19.17	19.17	47	47	47.25	33.90	19.37	23.62	7.09	n/a	30.0	7.09	22.0	6340
500	487	487	1194	1194	1200	861	492	600	180	n/a	762	180	559	2876
22	21.18	21.18	51	51	51.38	37.36	21.14	25.59	7.09	n/a	30.0	7.09	22.0	7870
550	538	538	1295	1295	1305	949	537	650	180	n/a	762	180	559	3570
24	23.19	23.19	55	55	55.38	42.20	24.06	27.13	7.28	n/a	32.0	7.28	22.0	9430
600	589	589	1397	1397	1407	1072	611	689	185	n/a	812	185	559	4277
26	24.92	24.92	57	57	57.5	42.99	24.49	28.74	8.07	n/a	32.0	8.07	22.0	11970
650	633	633	1448	1448	1461	1092	622	730	205	n/a	812	205	559	5430
28	26.93	26.93	61	61	61.5	46.18	25.87	30.51	8.07	n/a	32.0	8.07	23.5	13690
700	684	684	1549	1549	1562	1173	657	775	205	n/a	812	205	597	6210

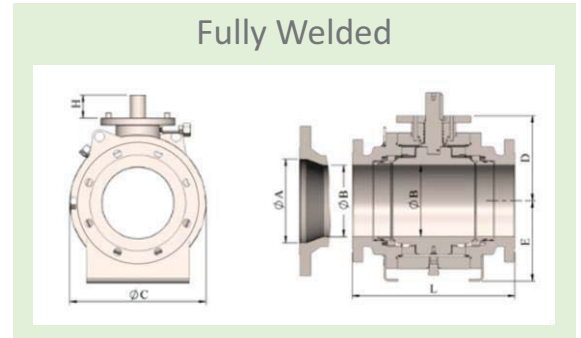
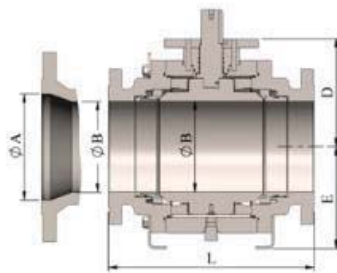
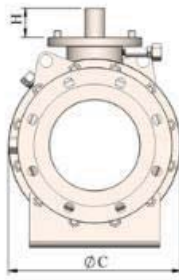
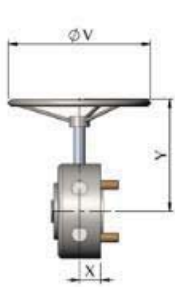

ASME CLASS 600 E1 Series

SIZE in/mm	A	B	L-WE	L-RF	L-RTJ	C	D	E	H	W	V	X	Y	Weight lb/kg
30	28.94	28.94	65	65	65.5	50.12	27.52	32.64	9.65	n/a	32.0	9.65	23.5	16420
750	735	735	1651	1651	1664	1273	699	829	245	n/a	812	245	597	7448
32	30.67	30.67	70	70	70.63	52.52	29.02	34.25	9.65	n/a	32.0	9.65	23.5	18670
800	779	779	1778	1778	1794	1334	737	870	245	n/a	812	245	597	8469
34	32.68	32.68	76	76	76.63	55.00	30.87	35.39	9.65	n/a	32.0	9.65	23.5	22830
850	830	830	1930	1930	1946	1397	784	899	245	n/a	812	245	597	10356
36	34.41	34.41	82	82	82.63	58.50	32.36	36.81	9.65	n/a	36.0	9.65	23.5	26630
900	874	874	2083	2083	2099	1486	822	935	245	n/a	914	245	597	12079
40	38.43	38.43	(*)	(*)	(*)	65.87	35.63	40.51	9.65	n/a	36.0	9.65	23.5	33990
1000	976	976	(*)	(*)	(*)	1673	905	1029	245	n/a	914	245	597	15418
42	40.16	40.16	(*)	(*)	(*)	69.49	38.11	42.01	9.65	n/a	36.0	9.65	23.5	40070
1050	1020	1020	(*)	(*)	(*)	1765	968	1067	245	n/a	914	245	597	18175
48	45.91	45.91	85.88	85.88	(*)	79.88	44.37	47.87	9.65	n/a	36.0	9.65	25.0	55680
1200	1166	1166	2181	2181	(*)	2029	1127	1216	245	n/a	914	245	635	25256
54	51.65	51.65	(*)	(*)	(*)	89.57	46.85	50.63	9.65	n/a	36.0	9.65	25.0	79757
1350	1312	1312	(*)	(*)	(*)	2275	1190	1286	245	n/a	914	245	635	36130
56	57.40	57.40	(*)	(*)	(*)	92.64	50.39	54.37	11.02	n/a	36.0	11.02	25.0	85250
1400	1458	1458	(*)	(*)	(*)	2353	1280	1381	280	n/a	914	280	635	38669

Note: (*) Upon Request. For dimensions & weights in larger sizes consult the factory.
Dimensions C, D, E, H, V, X, Y and weights are subject to change without notice.

JBT-A/JBT-AM/JBT-AF/JBT-AT 900 Plate Trunnion Ball Valve

ASME CLASS 900 E1 Series

SIZE in/mm	A	B	L-WE	L-RF	L-RTJ	C	D	E	H	W	V	X	Y	Weight lb/kg
6	5.91	5.91	24	24	24.12	15.00	9.45	9.65	2.56	n/a	16.0	2.56	8.75	720
150	150	150	610	610	613	381	240	245	65	n/a	406	65	292	327
8	7.91	7.91	29	29	29.12	18.50	15.08	13.58	3.54	n/a	20.0	3.54	16.5	1276
200	201	201	737	737	740	470	383	300	90	n/a	508	90	419	580
10	9.92	9.92	33	33	33.12	21.65	13.78	14.80	3.74	n/a	20.0	3.74	16.5	2110
250	252	252	838	838	841	550	350	345	95	n/a	508	95	419	957
12	11.93	11.93	38	38	38.12	24.02	14.80	18.11	4.72	n/a	24.0	4.72	16.5	2930
300	303	303	965	965	968	610	376	376	120	n/a	610	120	419	1329
14	12.68	12.68	40.5	40.5	40.88	27.56	16.46	18.31	4.72	n/a	24.0	4.72	16.5	3610
350	322	322	1029	1029	1038	700	418	460	120	n/a	610	120	419	1637
16	14.69	14.69	44.5	44.5	44.88	30.98	18.62	20.87	5.71	n/a	28.0	5.71	16.5	4360
400	373	373	1130	1130	1140	787	473	465	145	n/a	711	145	419	1978
18	16.65	16.65	48	48	48.5	33.50	19.13	20.28	5.71	n/a	28.0	5.71	16.5	6100
450	423	423	1219	1219	1232	851	486	530	145	n/a	711	145	419	2767
20	18.54	18.54	52	52	52.5	37.40	21.85	25.59	5.71	n/a	30.0	5.71	22.0	8240
500	471	471	1321	1321	1334	950	555	515	145	n/a	762	145	559	3738
22	20.55	20.55	(*)	(*)	(*)	40.51	22.05	25.59	8.11	n/a	30.0	8.11	22.0	10220
550	522	522	(*)	(*)	(*)	1029	560	660	206	n/a	762	206	559	4636
24	22.44	22.44	61	61	61.75	43.74	24.37	27.52	9.65	n/a	32.0	9.65	22.0	12250
600	570	570	1549	1549	1568	1111	619	699	245	n/a	812	245	559	5557

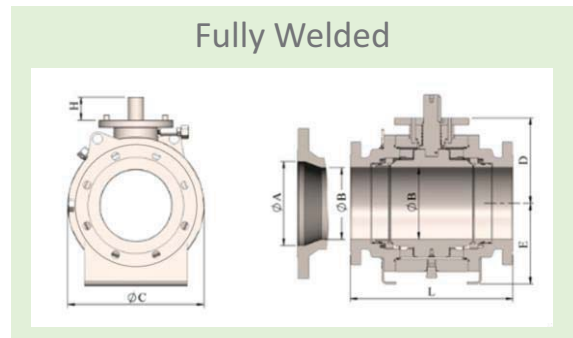
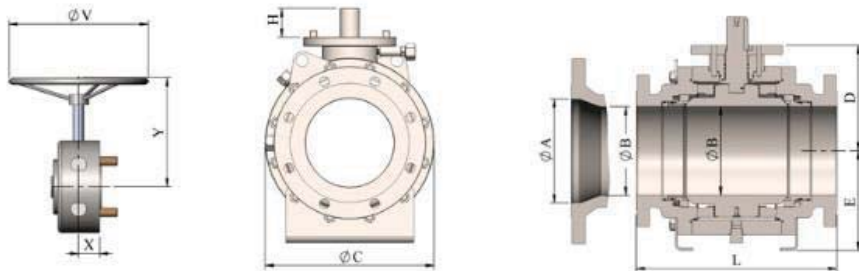

ASME CLASS 900 E1 Series

SIZE in/mm	A	B	L-WE	L-RF	L-RTJ	C	D	E	H	W	V	X	Y	Weight lb/kg
26	24.29	24.29	(*)	(*)	(*)	47.24	26.26	29.88	9.65	n/a	32.0	9.65	22.0	15540
650	617	617	(*)	(*)	(*)	1200	667	759	245	n/a	812	245	559	7049
28	26.18	26.18	(*)	(*)	(*)	50.75	27.87	31.89	9.65	n/a	32.0	9.65	23.5	17790
700	665	665	(*)	(*)	(*)	1289	708	810	245	n/a	812	245	597	8069
30	28.03	28.03	(*)	(*)	(*)	53.39	29.65	32.76	9.65	n/a	32.0	9.65	23.5	21340
750	712	712	(*)	(*)	(*)	1356	753	832	245	n/a	812	245	597	9680
32	29.92	29.92	(*)	(*)	(*)	57.52	31.89	35.87	9.65	n/a	32.0	9.65	23.5	24250
800	760	760	(*)	(*)	(*)	1461	810	911	245	n/a	812	245	597	11000
34	31.81	31.81	(*)	(*)	(*)	60.98	33.39	37.76	9.65	n/a	32.0	9.65	23.5	29690
850	808	808	(*)	(*)	(*)	1549	848	959	245	n/a	812	245	597	13467
36	33.66	33.66	(*)	(*)	(*)	64.37	34.76	40.12	10.83	n/a	36.0	10.83	23.5	34610
900	855	855	(*)	(*)	(*)	1635	883	1019	275	n/a	914	275	597	15699
40	37.64	37.64	(*)	(*)	(*)	71.26	38.27	44.09	10.83	n/a	36.0	10.83	25.0	44170
1000	956	956	(*)	(*)	(*)	1810	972	1120	275	n/a	914	275	635	20035
42	39.61	39.61	(*)	(*)	(*)	74.33	41.73	47.24	10.83	n/a	36.0	10.83	25.0	52070
1050	1006	1006	(*)	(*)	(*)	1888	1060	1200	275	n/a	914	275	635	23619
48	45.24	45.24	(*)	(*)	(*)	81.50	43.74	50.39	10.83	n/a	36.0	10.83	25.0	72370
1200	1149	1149	(*)	(*)	(*)	2070	1111	1280	275	n/a	914	275	635	32826

Note: (*) Upon Request. For dimensions & weights in larger sizes consult the factory. Dimensions C, D, E, H, V, X, Y and weights are subject to change without notice.



**JDV
CONTROL
VALVES**

JBT-A/JBT-AM/JBT-AF/JBT-AT 1500~2500# Plate Trunnion Ball Valve

ASME CLASS 1500 E1 Series

SIZE in/mm	A	B	L-WE	L-RF	L-RTJ	C	D	E	H	W	V	X	Y	Weight lb/kg
6	5.67	5.67	27.76	27.76	27.99	16.89	10.98	12.64	3.74	n/a	24.0	3.74	13.8	1056
150	144	144	705	705	711	429	279	321	95	n/a	610	95	350	480
8	7.56	7.56	32.76	32.76	33.11	20.51	13.23	16.54	3.78	n/a	28.0	3.78	16.5	1804
200	192	192	832	832	841	521	336	322	96	n/a	711	96	419	820
10	9.41	9.41	39.02	39.02	39.37	25.75	15.39	16.54	4.53	n/a	28.0	4.53	16.5	3300
250	239	239	991	991	1000	654	391	420	115	n/a	711	115	419	1500
12	11.30	11.30	44.49	44.49	45.11	27.17	16.77	20.28	5.71	n/a	28.0	5.71	16.5	4950
300	287	287	1130	1130	1146	690	426	420	145	n/a	711	145	419	2250
14	12.40	12.40	49.49	49.49	50.24	34.25	19.25	20.35	5.91	n/a	30.0	5.91	22.0	6270
350	315	315	1257	1257	1276	870	489	515	150	n/a	762	150	559	2850
16	14.17	14.17	54.49	54.49	55.39	34.84	19.57	27.56	5.91	n/a	30.0	5.91	22.0	8954
400	360	360	1384	1384	1407	885	497	517	150	n/a	762	150	559	4070
18	15.94	15.94	60.51	60.51	61.38	42.87	23.27	29.88	7.87	n/a	32.0	7.87	22.0	13629
450	405	405	1537	1537	1559	1089	591	700	200	n/a	812	200	559	6195
20	17.91	17.91	65.51	65.51	66.38	46.38	28.50	35.04	9.65	n/a	32.0	9.65	25.0	19965
500	455	455	1664	1664	1686	1178	724	759	245	n/a	812	245	635	9075
24	20.87	20.87	*	*	77.64	55.87	32.01	35.04	9.65	n/a	32.0	9.65	25.0	31416
600	530	530	*	*	1972	1419	813	890	245	n/a	812	245	635	14280

ASME CLASS 2500 E1 Series

SIZE in/mm	A	B	L-WE	L-RF	L-RTJ	C	D	E	H	W	V	X	Y	Weight lb/kg
6	5.16	5.16	35.98	35.98	36.50	19.02	13.39	13.46	3.74	n/a	28.0	3.74	16.5	2116
150	131	131	914	914	927	483	340	342	95	n/a	711	95	419	952
8	7.05	7.05	40.24	40.24	40.87	24.80	16.30	17.13	4.33	n/a	28.0	4.33	16.5	3905
200	179	179	1022	1022	1038	630	414	395	110	n/a	711	110	419	1769
10	8.78	8.78	50.00	50.00	50.87	31.10	18.27	19.65	5.51	n/a	30.0	5.51	22.0	5715
250	223	223	1270	1270	1292	790	464	435	140	n/a	762	140	559	2589
12	10.43	10.43	55.98	55.98	56.89	34.25	20.51	0.00	5.51	n/a	32.0	5.51	22.0	7837
300	265	265	1422	1422	1445	870	521	499	140	n/a	812	140	559	3550

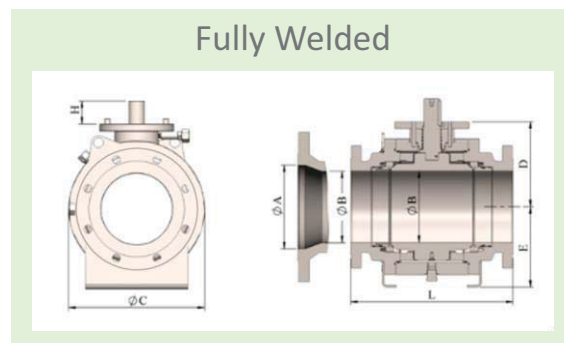
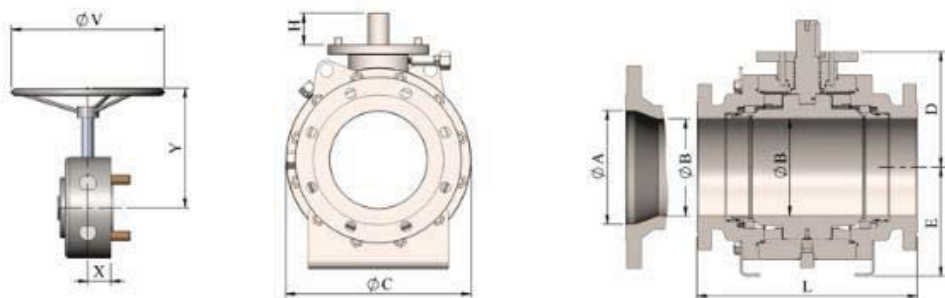

FOR E1 Series Reduced Bore Ball Valve

CLASS 150		CLASS 300		CLASS 600		CLASS 900		CLASS 1500		CLASS 2500	
SIZE in/mm	Weight lb/kg	SIZE in/mm	Weight lb/kg	SIZE in/mm	Weight lb/kg	SIZE in/mm	Weight lb/kg	SIZE in/mm	Weight lb/kg	SIZE in/mm	Weight lb/kg
8x6x8	407	8x6x8	481.8	8x6x8	642	8x6x8	968	8x6x8	1245	8x6x8	2530
200x150	185	200x150	219	200x150	292	200x150	440	200x150	566	200x150	1150
10x8x10	640	10x8x10	642.4	10x8x10	1210	10x8x10	1518	10x8x10	2248	10x8x10	4620
250x200	291	250x200	292	250x200	550	250x200	690	250x200	1022	250x200	2100
12x10x12	1016	12x10x12	1306.8	12x10x12	1784	12x10x12	2541	12x10x12	3872	12x10x12	7260
300x250	462	300x250	594	300x250	811	300x250	1155	300x250	1760	300x250	3300
14x10x14	1140	14x10x14	1414.6	14x10x14	2006	14x10x14	2728	14x10x14	4719	14x10x14	9017
350x250	518	350x250	643	350x250	912	350x250	1240	350x250	2145	350x250	4085
14x12x14	1342	14x12x14	1795.2	14x12x14	2519	14x12x14	3597	14x12x14	5500	14x12x14	10143
350x300	610	350x300	816	350x300	1145	350x300	1635	350x300	2500	350x300	4595
16x12x16	1536	16x12x16	2123	16x12x16	2966	16x12x16	3806	16x12x16	6160	16x12x16	12117
400x300	698	400x300	965	400x300	1348	400x300	1730	400x300	2800	400x300	5489
16x14x16	1804	16x14x16	2475	16x14x16	2383	16x14x16	3740	16x14x16	7139	16x14x16	14399
400x350	820	400x350	1125	400x350	1083	400x350	1700	400x350	3245	400x350	6745
18x14x18	2332	18x14x18	3504.6	18x14x18	3696	18x14x18	5368	18x14x18	10934	18x14x18	22399
450x350	1060	450x350	1593	450x350	1680	450x350	2440	450x350	4970	450x350	10495
20x16x20	2420	20x16x20	3658.6	20x16x20	4587	20x16x20	6325	20x16x20	11297	20x16x20	23399
500x400	1100	500x400	1663	500x400	2085	500x400	2875	500x400	5135	500x400	10795
24x20x24	4334	24x20x24	5854.2	24x20x24	7146	24x20x24	11880	24x20x24	23925	24x20x24	50099
600x500	1970	600x500	2661	600x500	3248	600x500	5400	600x500	10875	600x500	22795
30x24x30	7150	30x24x30	9864.8	30x24x30	12690	30x24x30	19140	30x24x30	36821	30x24x30	77499
750x600	3250	750x600	4484	750x600	5768	750x600	8700	750x600	16680	750x600	35295

Note: (*) Upon Request. For dimensions & weights in larger sizes consult the factory. Dimensions C, D, E, H, V, X, Y and weights are subject to change without notice.



**JDV
CONTROL
VALVES**

Valves Components Assembly / Cryogenic Trunnion Ball Valve

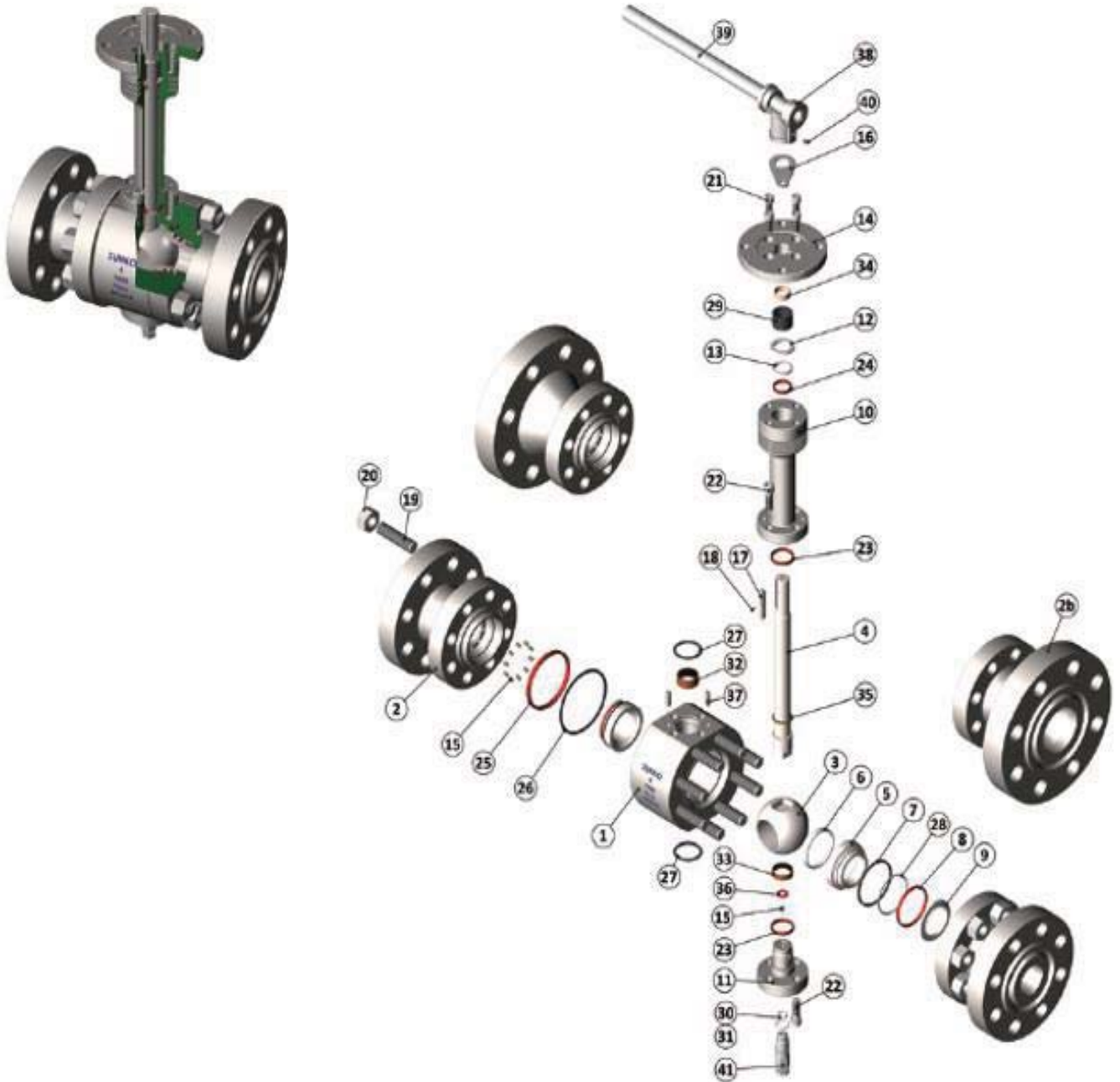

Technical Specifications

ITEM	PART	ASME CLASS	STAINLESS STEEL -101°C (NACE)	STAINLESS STEEL -196°C (NACE)
1	Body	All	A182 Gr.316	A182 Gr.316
2	Tailpiece	All	A182 Gr.316	A182 Gr.316
2b	RB Tailpiece	All	A182 Gr.316	A182 Gr.316
3	Ball	All	A182 Gr.316	A182 Gr.316
4	Stem	All	A182 Gr.316	A182 Gr.316
5	Seat Retainer	All	A182 Gr.316	A182 Gr.316
6	Seat Insert	All	PCTFE	PCTFE
7	Fire-safe Gasket	All	G raphite	G raphite
8	Seat Lipseal	All	316 S.S.+RPTFE	Elgiloy+RPTFE
9	Seat Plate	All	A182 Gr.316	A182 Gr.316
10	Gland	All	A182 Gr.316	A182 Gr.316
11	Post Trunnion	All	A182 Gr.316	A182 Gr.316
12	Stop Ring	All	A182 Gr.316	A182 Gr.316
13	Gland Ring	All	A182 Gr.316	A182 Gr.316
14	Gland Plate	All	A182 Gr.316	A182 Gr.316
15	Spring	All	Inconel X750	Inconel X750
16	Locking Plate	All	Stainless Steel	Stainless Steel
17	Key	All	Stainless Steel	Stainless Steel
18	Spring Pin	All	AISI 1588	AISI 1588
19	Body Studs	All	A193 Gr.B8M	A193 Gr.B8M
20	Body Nuts	All	A194 Gr.8M	A194 Gr.8M
21	Gland Bolt	All	A193 Gr.B8M	A193 Gr.B8M
22	Trunnion Bolt	All	A193 Gr.B8M	A193 Gr.B8M
23	Trunnion Lipseal	All	316 S.S.+RPTFE	Elgiloy+RPTFE
24	Stem Lipseal	All	316 S.S.+RPTFE	Elgiloy+RPTFE
25	Body Lipseal	All	316 S.S.+RPTFE	Elgiloy+RPTFE
26	Body Fire-safe Gasket	900 through 2500	Spiral Wound Gasket	Spiral Wound Gasket
27	Trunnion Fire-safe Gasket	All	Spiral Wound Gasket	Spiral Wound Gasket
28	Lipseal Back-up Ring	600 through 2500	RPTFE	RPTFE
29	Stem Packing	All	Graphite	Graphite
30	O-Rings	All	PTFE	PTFE
31	O-Rings	All	PTFE	PTFE
32	Stem Bearing	All	SS + Filled PTFE	SS + Filled PTFE
33	Trunnion Bearing	All	SS + Filled PTFE	SS + Filled PTFE
34	Stem Bearing	All	SS + Filled PTFE	SS + Filled PTFE
35	Stem Thrust Bearing	All	PCTFE	PCTFE
36	Ball Thrust Bearing	All	PCTFE	PCTFE
37	Parallel Pins	All	A276 Gr.316	A276 Gr.316
38	Handle Guide	All	A216 Gr.WCB+Zn	A216 Gr.WCB+Zn
39	Pipe	All	Carbon Steel+Painting	Carbon Steel+Painting
40	Handle Screw	All	Stainless Steel	Stainless Steel
41	Vent Valve	All	A276 Gr.316	A276 Gr.316



Valves Components Assembly / Plate trunnion Ball Valve

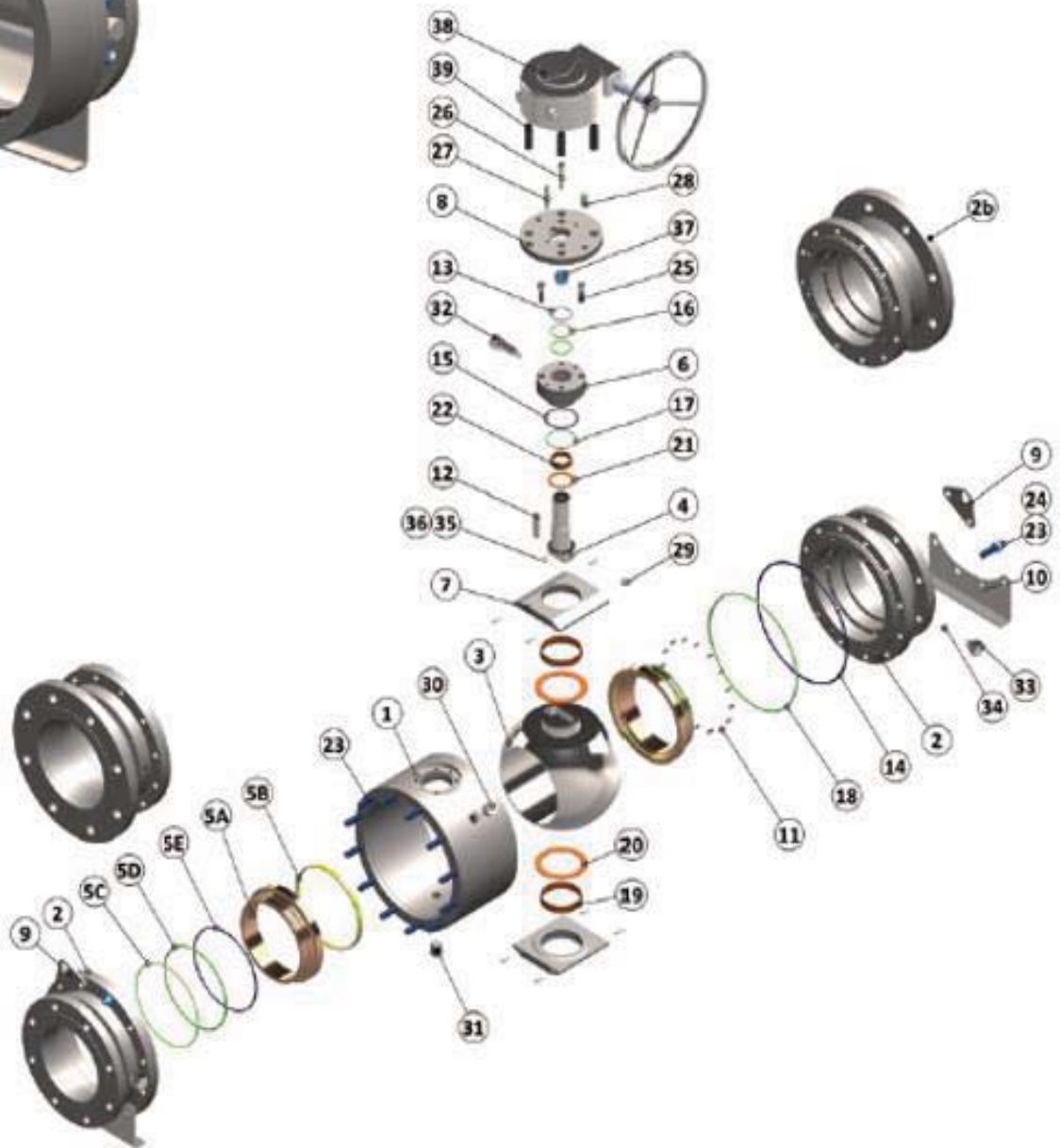

Technical Specifications

ITEM	PART	ASME CLASS	STANDARD (NACE)	LOW TEMP (NACE)	STAINLESS STEEL (NACE)
1	Body	All	A105	A350 LF2	A182 Gr.316
2	Tailpiece	All	A105	A350 LF2	A182 Gr.316
3	Ball	150 through 900	A105 + ENP	A350 LF2 + ENP	A182 Gr.316
	Ball	1500 & 2500	4130/4140 + ENP	4130/4140 + ENP	A564 Type 630
4	Stem	150 through 900	4130/4140 + ENP	4130/4140 + ENP	A182 Gr.316
		1500 & 2500	4130/4140 + ENP	4130/4140 + ENP	A564 Type 630
5A	Seat Ring	150 through 2500	A105+ENP	A350 LF2+ENP	A182 Gr.316
5B	Seat Insert	150 through 300	Filled PTFE	Filled PTFE	Filled PTFE
		600 through 2500	Nylon / Devlon / PEEK	Nylon / Devlon / PEEK	Nylon / Devlon / PEEK
5C	O-Ring	All	HNBR / FKM	HNBR / FKM	HNBR / FKM
5D	O-Ring	All	HNBR / FKM	HNBR / FKM	HNBR / FKM
5E	Seat Fire Safe Seal	All	Graphite	Graphite	Graphite
6	Gland	All	A105	A350 LF2	A182 Gr.316
7	Plate Trunnion	All	4130/4140 + ENP	4130/4140 + ENP	A182 Gr.316
8	Gland Plate	All	A105	A350 LF2	A182 Gr.316
9	Lifting Plate	All	Carbon Steel	Carbon Steel	Stainless Steel
10	Leg Plate	All	Carbon Steel	Carbon Steel	Stainless Steel
11	Seat Spring	All	Inconel X750	Inconel X750	Inconel X750
12	Key	All	Carbon Steel	Carbon Steel	Stainless Steel
13	Stem Packing	All	Graphite	Graphite	Graphite
14	Body Fire Safe Seal	All	Spiral Wound Gasket	Spiral Wound Gasket	Spiral Wound Gasket
15	Gland Fire Safe Seal	All	Spiral Wound Gasket	Spiral Wound Gasket	Spiral Wound Gasket
16	Stem O-Ring	All	HNBR / FKM	HNBR / FKM	HNBR / FKM
17	Gland O-Ring	All	HNBR / FKM	HNBR / FKM	HNBR / FKM
18	Body O-Ring	All	HNBR / FKM	HNBR / FKM	HNBR / FKM
19	DU Bearing	All	CS + Filled PTFE	SS + Filled PTFE	SS + Filled PTFE
20	DU Thrust Bearing	All	CS + Filled PTFE	SS + Filled PTFE	SS + Filled PTFE
21	Stem Thrust Bearing	All	CS + Filled PTFE	SS + Filled PTFE	SS + Filled PTFE
22	Stem DU Bearing	All	CS + Filled PTFE	SS + Filled PTFE	SS + Filled PTFE
23	Body Studs	All	A193 Gr.B7M	A193 Gr.L7M	A193 Gr.B8M
24	Body Nuts	All	A194 Gr.2HM	A194 Gr.7M	A194 Gr.8M
25	Gland Bolt	All	A193 Gr.B7M	A193 Gr.L7M	A193 Gr.B8M
26	Gland Plate Bolt	All	A193 Gr.B7M	A193 Gr.L7M	A193 Gr.B8M
27	Parallel Pins	All	AISI 1045	AISI 1045	Stainless Steel
28	Parallel Pins	All	AISI 1045	AISI 1045	Stainless Steel
29	Parallel Pins	All	A276 Gr.316	A276 Gr.316	A276 Gr.316
30	Vent Valve	All	A276 Gr.316	A276 Gr.316	A276 Gr.316
31	Plug	All	A276 Gr.316	A276 Gr.316	A276 Gr.316
32	Stem Injection Fitting	All	A105+Zn (Main Material)	Stainless Steel	A276 Gr.316
33	Seat Injection Fitting	All	A105+Zn (Main Material)	Stainless Steel	A276 Gr.316
34	Seat Check Valve	All	A276 Gr.316	A276 Gr.316	A276 Gr.316
35	Anti-static Ball	All	316 S.S.	316 S.S.	316 S.S.
36	Anti-Static Spring	All	316 S.S.	316 S.S.	316 S.S.
37	Gear Nuts	All	A194 Gr.2HM	A194 Gr.7M	A194 Gr.8M
38	Gear	All	A216 Gr.WCB	A216 Gr.WCB	A216 Gr.WCB
39	Gear Bolts	All	A193 Gr.B7M	A193 Gr.L7M	A193 Gr.B8M



**JDV
CONTROL
VALVES**

Valves Components Assembly Post Trunnion Ball Valve

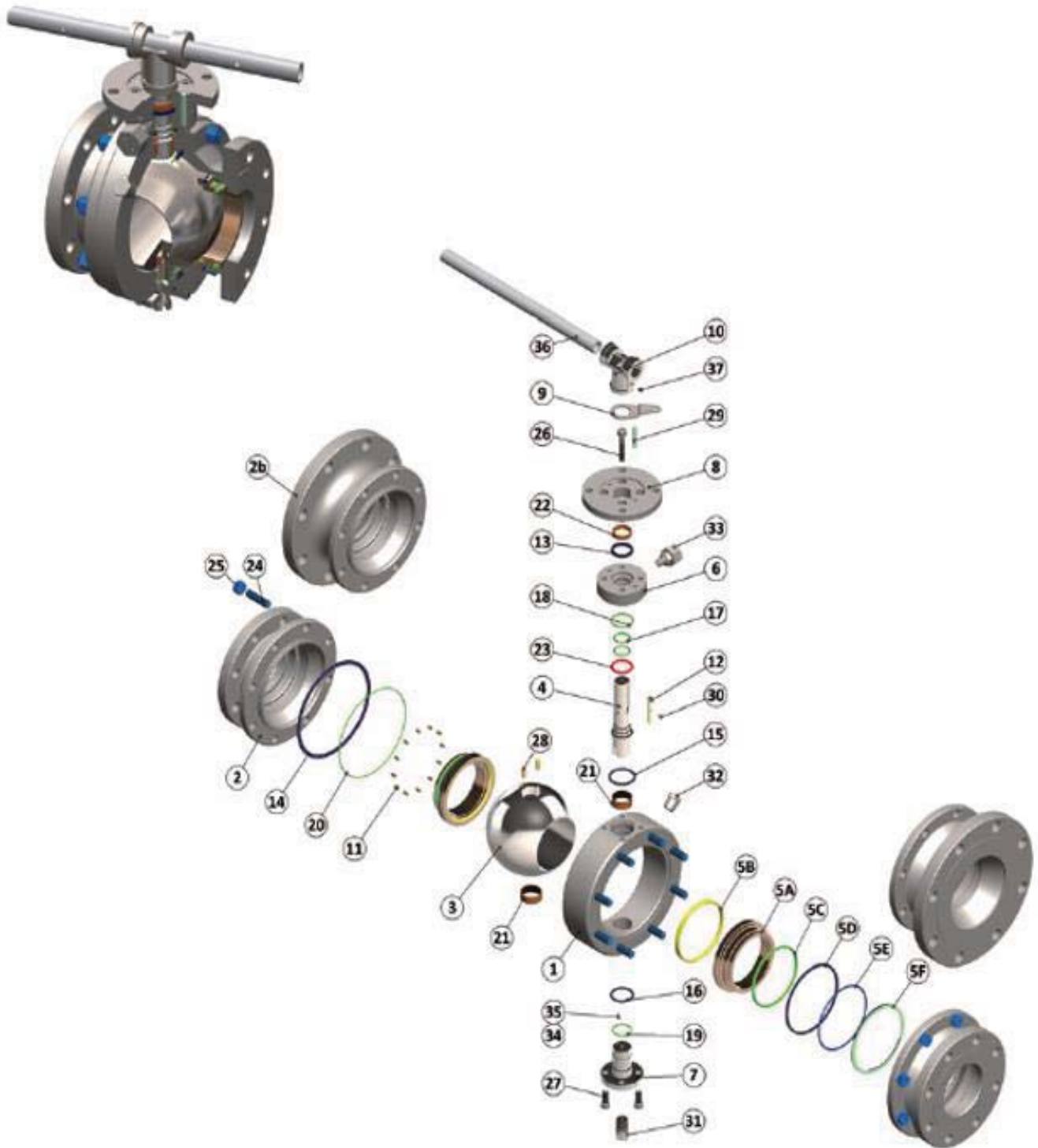

Technical Specifications

ITEM	PART	ASME CLASS	STANDARD (NACE)	LOW TEMP (NACE)	STAINLESS STEEL (NACE)
1	Body	All	A105	A350 LF2	A182 Gr.316
2	Tailpiece	All	A105	A350 LF2	A182 Gr.316
2b	RB Tailpiece	All	A105	A350 LF2	A182 Gr.316
3	Ball	150 through 900	A105 + ENP	A350 LF2 + ENP	A182 Gr.316
		1500 & 2500	4130/4140 + ENP	4130/4140 + ENP	A564 Type 630
4	Stem	150 through 900	4130/4140 + ENP	4130/4140 + ENP	A182 Gr.316
		1500 & 2500	4130/4140 + ENP	4130/4140 + ENP	A564 Type 630
5A	Seat Ring	150 through 2500	A105+ENP	A350 LF2+ENP	A182 Gr.316
5B	Seat Insert	150 through 300	Filled PTFE	Filled PTFE	Filled PTFE
		600 through 2500	Nylon / Devlon / PEEK	Nylon / Devlon / PEEK	Nylon / Devlon / PEEK
5C	O-Ring	All	HNBR / FKM	HNBR / FKM	HNBR / FKM
5D	Seat Fire Safe Seal	All	Graphite	Graphite	Graphite
5E	Back-up Ring	All	PTFE	PTFE	PTFE
5F	Seat Plate	All	A105+ENP	A350 LF2+ENP	A182 Gr.316
6	Gland	All	A105	A350 LF2	A182 Gr.316
7	Post Trunnion	All	A105	A350 LF2	A182 Gr.316
8	Gland Plate	All	A105	A350 LF2	A182 Gr.316
9	Locking Plate	All	Carbon Steel+Zn	Carbon Steel+Zn	Stainless Steel
10	Handle Guide	All	A216 Gr.WCB	A216 Gr.WCB	A216 Gr.WCB+Zn
11	Seat Spring	All	Inconel X750	Inconel X750	Inconel X750
12	Key	All	Carbon Steel	Carbon Steel	Stainless Steel
13	Stem Packing	All	Graphite	Graphite	Graphite
14	Body Fire Safe Seal	All	Spiral Wound Gasket	Spiral Wound Gasket	Spiral Wound Gasket
15	Gland Fire Safe Seal	All	Spiral Wound Gasket	Spiral Wound Gasket	Spiral Wound Gasket
16	Trunnion Fire Safe Seal	All	Spiral Wound Gasket	Spiral Wound Gasket	Spiral Wound Gasket
17	Stem O-Ring	All	HNBR / FKM	HNBR / FKM	HNBR / FKM
18	Gland O-Ring	All	HNBR / FKM	HNBR / FKM	HNBR / FKM
19	Trunnion O-Ring	All	HNBR / FKM	HNBR / FKM	HNBR / FKM
20	Body O-Ring	All	HNBR / FKM	HNBR / FKM	HNBR / FKM
21	DU Bearing	All	CS + Filled PTFE	SS + Filled PTFE	SS + Filled PTFE
22	DU Bearing	All	CS + Filled PTFE	SS + Filled PTFE	SS + Filled PTFE
23	Stem Thrust Bearing	All	CS + Filled PTFE	SS + Filled PTFE	SS + Filled PTFE
24	Body Studs	All	A193 Gr.B7M	A193 Gr.L7M	A193 Gr.B8M
25	Body Nuts	All	A194 Gr.2HM	A194 Gr.7M	A194 Gr.8M
26	Gland Bolt	All	A193 Gr.B7M	A193 Gr.L7M	A193 Gr.B8M
27	Trunnion Bolt	All	A193 Gr.B7M	A193 Gr.L7M	A193 Gr.B8M
28	Parallel Pins	All	AISI 1045	AISI 1045	Stainless Steel
29	Parallel Pins	All	AISI 1045	AISI 1045	Stainless Steel
30	Spring Pins	All	AISI 1568	AISI 1568	AISI 1568
31	Vent Valve	All	A105+Zn (Main Material)	A276 Gr.316	A276 Gr.316
32	Plug	All	A276 Gr.316	A276 Gr.316	A276 Gr.316
33	Stem Injection Fitting	All	A105+Zn (Main Material)	A276 Gr.316	A276 Gr.316
34	Anti-static Ball	All	316 S.S.	316 S.S.	316 S.S.
35	Anti-Static Spring	All	316 S.S.	316 S.S.	316 S.S.
36	Pipe	All	Carbon Steel+Painting	Carbon Steel+Painting	Carbon Steel+Painting
37	Handle Screw	All	Carbon Steel+Painting	Carbon Steel+Painting	Carbon Steel+Painting



HOW TO ORDER

JBT-A/M/F/T Type **A** → **B** → **C** → **D** → **E**

☆ A. SPECIFICATION	☆ B. BODYMATL	☆ C. BORE	☆ D. END CONNECTIONS	☆ E. OPERATOR
C1 ASME CLASS 150	02 A105N	A Full	1 RF/RF	1 Lever
C2 ASME CLASS 300	03 A350-LF2	B Reduced	2 WE/WE	1A Extension lever
C3 ASME CLASS 600	04 A182-F316	C Venturi	3 RF/WE	2 Worm gear
C4 ASME CLASS 900		D All Others	4 RTJ/RTJ	2A Extension worm gear
C5 ASME CLASS 1500			5 RTJ/WE	4 Subsea gear
C6 ASME CLASS 2500			6 All Others	4A Subsea gear 300 feet +
				7 Direct stem
				7A Extension direct stem
				8 Worm gear/adapted
				8A Extension worm gear/adapted
				22 Square
				22A Extension square NutIMtg/Flg
				23 Worm gear with 2" square operating nut
				23A Worm gear with right angle pinion shaft extension and 2" square operating nut



■ HEADQUARTERS

NO.6-1, QINGNIAN RD., YANGMEI DIST., TAOYUAN CITY 326, TAIWAN
Tel: 886-3-4965066 Fax: 886-3-4965300 E-mail: sales@jdv.com.tw



Copyright 2021/05. All rights are reserved by JDV.
The technical data and content may be changed without prior notice.