

## 1/2" – 8"

SDV Diaphragm Valves are ideally suited for Shut-off, Flow Control and Throttling of corrosive and abrasive process media in either liquid or gaseous state.

### Modular Design

Valves are available with handwheel for manual operation as per standard.

The sturdy design bodies are made of cast steel 1.0619 (WCB), epoxy coating RAL 5005 signal-blue or stainless steel casting 1.4408 (CF-8M), with resistant linings such as PFA or PFA-AS (conductive).

Proven PTFE/EPDM-diaphragms assure faultless closing function at any time.



### Main Features

- Heavy-duty, robust construction, maintenance-free
- Bubble-tight shut-off throughout the full pressure and temperature range
- Spindle protected against atmospheric corrosion
- Force limiting device protecting diaphragm from cold flow and other deformations, high life cycle
- Yellow sight indicator showing actual position of diaphragm
- Easy replacement of components on site
- Flanges acc. to ANSI 150lbs (option: DIN standards) for installation into existing piping systems

 **Conformity according to European Pressure Equipment Directive 2014/68/EU (PED)**

### Options



#### Sliding Spindle

Body WCB/PFA, for external actuators



#### Automated Valve

Body CF-8M/PFA, with pneum. actuator, el. position indicator and solenoid valve



#### Limit Switch Box



#### Safety Padlock

### Operating Conditions

- Temperature range from -22°F up to +302°F, depending on lining material
- Pressure range from 0.19 psia up to 232 psi, depending on size

### Testing / Marking

- Pressure- and tightness testing acc. to EN 12266-1, leakage rate A, resp. API 598.
- Marking of valves on body and name plate acc. to EN 19.
- Material- resp. test certificates acc. to EN 10204-3.1/2.2/2.1

### Construction of Valve

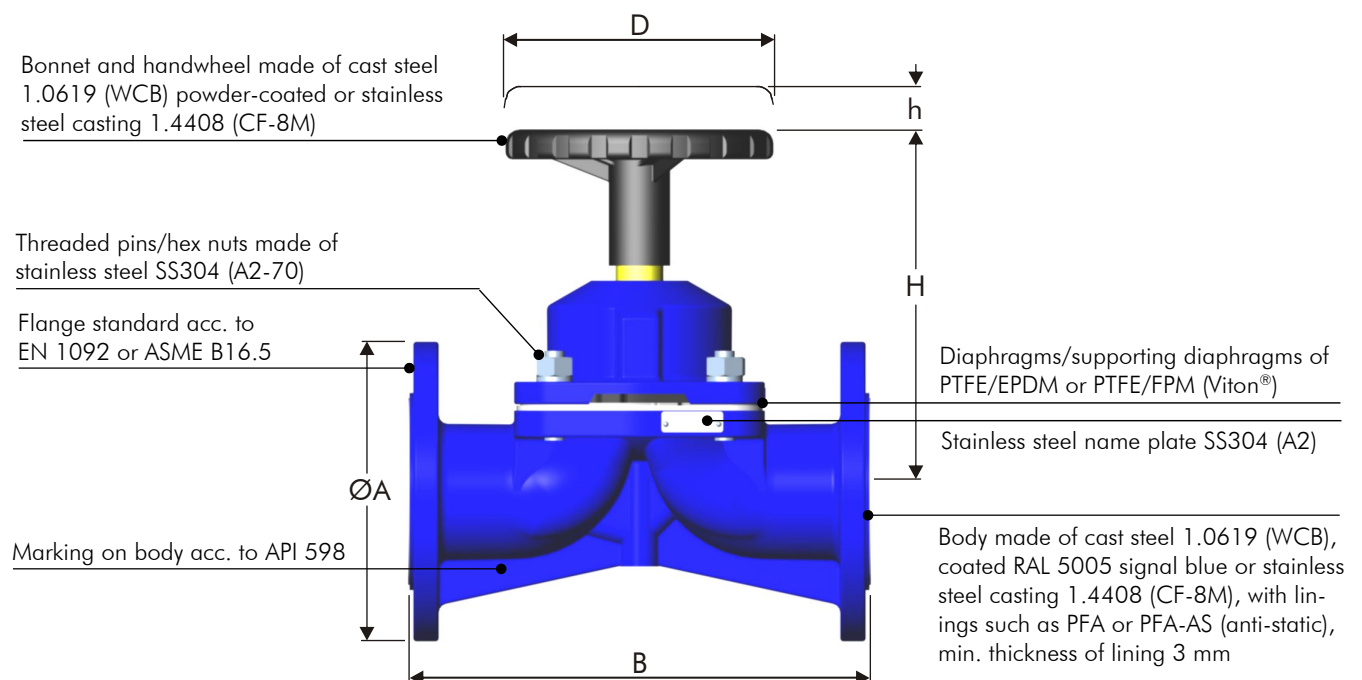

### Dimensions inch

Size nom.	$\varnothing A$	B	D	H	h Stroke	Revol. per stroke	Weight lbs	PS max. psi	Cv-Value max. (usg/min)
1/2"	3.74	5.12	3.35	4.53	0.31	4.5	5.50	232	9
3/4"	4.13	5.91	3.35	4.61	0.31	4.5	6.60	232	12
1"	4.25	5.75	3.35	4.88	0.39	5.5	7.70	232	17
1 1/4"	5.50	7.09	3.35	5.28	0.47	7.0	11.44	232	26
1 1/2"	5.00	6.85	4.72	6.81	0.94	12.0	13.86	232	43
2"	6.00	7.87	4.72	7.32	1.18	15.0	19.80	232	75
2 1/2"	7.28	11.42	7.09	8.19	1.18	12.0	29.70	145	110
3"	7.50	10.24	7.09	9.17	1.34	13.5	37.18	116	155
4"	9.00	12.87	9.84	11.10	1.57	13.5	66.66	102	232
5"	9.84	15.75	9.84	13.58	2.05	17.5	94.60	102	371
6"	11.00	16.38	15.75	16.22	2.36	15.0	130.90	102	524
8" <sup>1)</sup>	13.38	23.62	15.75	19.25	3.54	22.5	268.40	73	754

Face to face B acc. to MSS SP-88 (1/2", 3/4", 1 1/4", 2 1/2", 5", 8" acc. to EN 558-1 range 1

<sup>1)</sup> above PS max. 3 bar: supplier to be contacted

**Pressure-/Temperature Diagram**

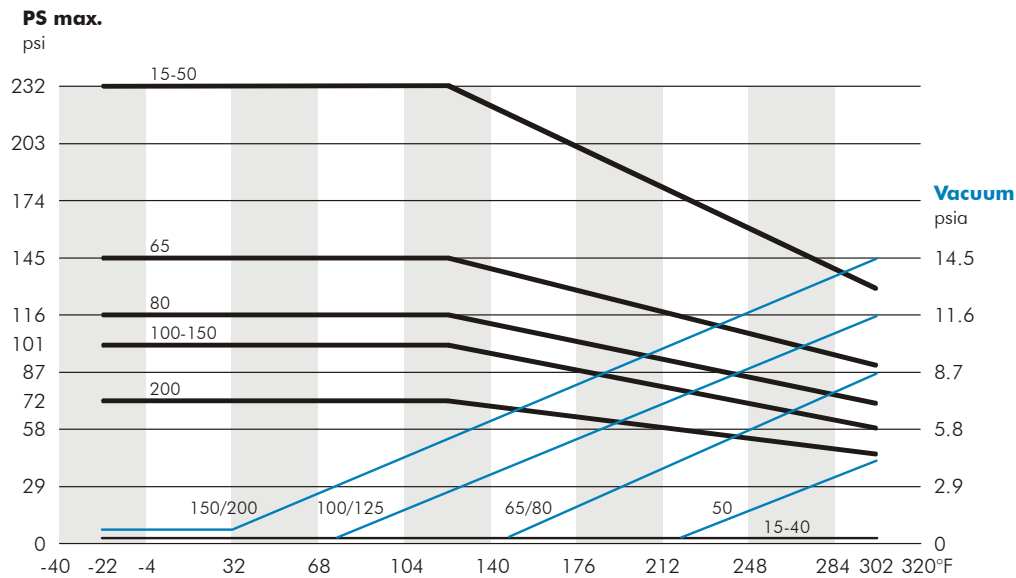

**Options**

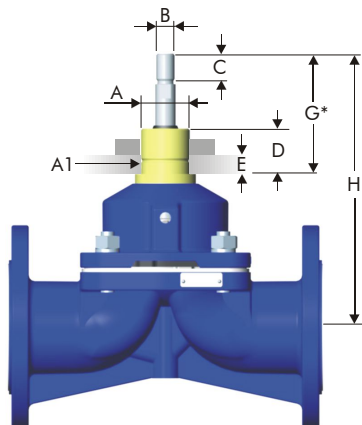

**Type Ss**  
Bonnet with sliding spindle for easy actuation with pneumatic or electric actuators (not suitable for Swissfluid type actuators)



**Bonnet Type Stroke Actuator**  
optional with limit switch box and filter regulator, E/P positioner, solenoid valve

**Dimensions** inch

Size nom.	A	A1	B	C	D	E	G	H	PS max. psi	Closing Forces lbf
1/2"	M30x1.5	1.26	M12	1.02	1.02	0.39	4.33	6.61	232	182
3/4"	M30x1.5	1.26	M12	1.02	1.02	0.39	4.33	6.69	232	232
1"	M30x1.5	1.26	M12	1.02	1.02	0.39	4.33	7.05	232	288
1 1/4"	M30x1.5	1.26	M12	1.02	1.02	0.39	4.33	7.48	232	352
1 1/2"	M40x1.5	1.57	M16	1.10	1.38	0.47	4.33	8.19	232	431
2"	M40x1.5	1.57	M16	1.10	1.38	0.47	4.33	8.70	232	595
2 1/2"	M48x1.5	1.89	M18x1.5	1.38	1.50	0.47	4.33	9.13	145	765
3"	M48x1.5	1.89	M18x1.5	1.38	1.50	0.47	4.33	10.12	116	905
4"	M52x1.5	2.05	M24x2	1.38	1.50	0.47	4.33	11.42	102	1,130
5"	M52x1.5	2.05	M24x2	1.38	1.50	0.47	4.33	12.01	102	1,690
6"	M62x1.5	2.44	M30x2	1.38	1.50	0.47	4.33	14.06	102	3,310
8"	M62x1.5	2.44	M30x2	1.38	1.50	0.47	4.33	17.01	73	4,300

**Construction of Linear Stroke Actuator** Sectional view and accessories

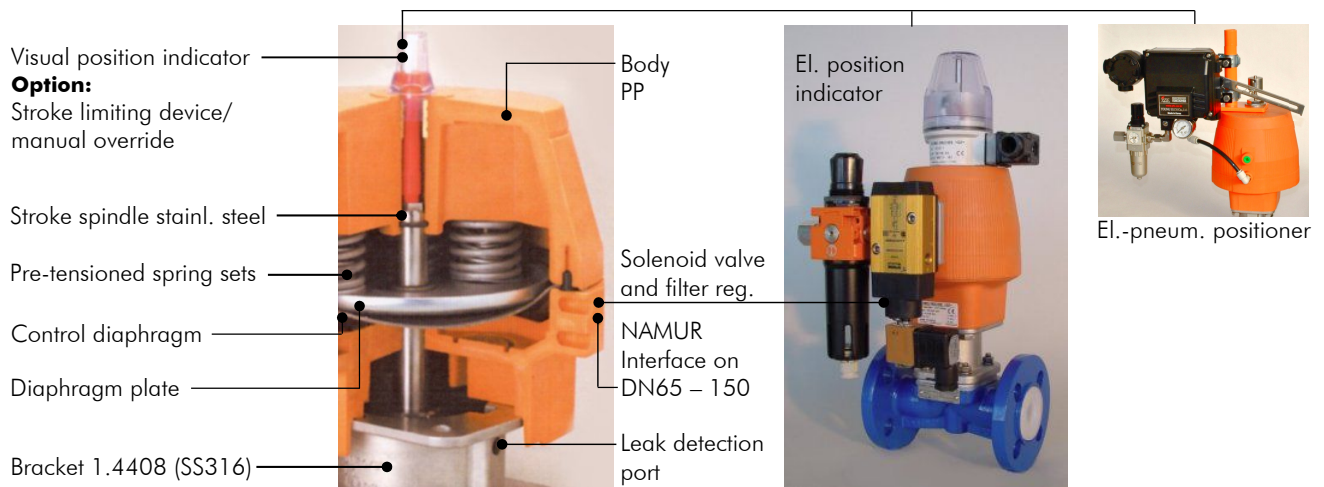

**Mounting Options** Dimensions inch

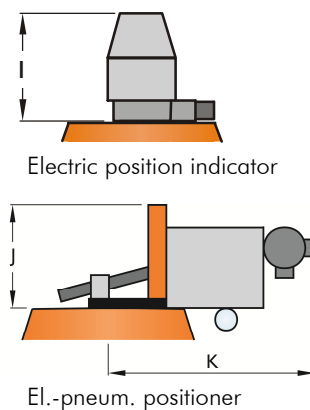
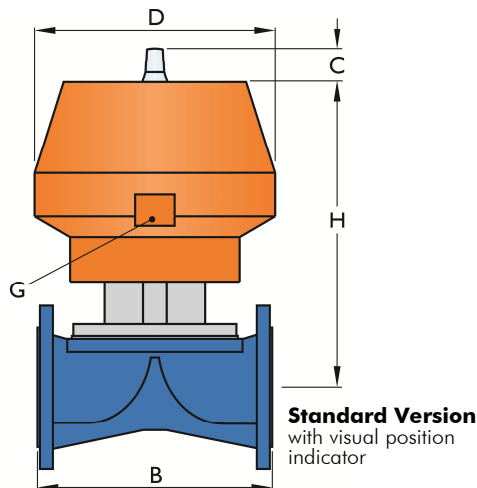

**Accessories**

- Electric position indicator
- Adapter mounting kit  
must be applied if valve with stroke limiter and manual override is combined with an electric position indicator
- Stroke limiter/manual override
- Mounting flange kit for positioner
- Electro-pneum. positioner
- 3/2-way solenoid valve for single-acting actuators
- 5/2-way solenoid valve for double-acting actuators
- Pneum. positioner
- NAMUR adapter plate

Size nom.	B	C	D	G	H	I	J	K	Weight lbs
1/2"	5.12	0.89	3.78	1/8"	8.31	3.94	6.30	11.42	10.56
3/4"	5.91	0.89	3.78	1/8"	8.39	3.94	6.30	11.42	11.66
1"	5.75	0.89	3.78	1/8"	8.94	3.94	6.30	11.42	13.42
1 1/4"	7.09	1.40	4.72	1/8"	9.96	3.94	6.30	11.42	17.16
1 1/2"	6.85	1.40	5.91	1/4"	11.18	3.94	6.30	11.42	28.16
2"	7.87	1.40	5.91	1/4"	11.89	3.94	6.30	11.42	33.66
2 1/2"	11.42	1.81	11.02	1/4"	14.41	5.08	6.30	11.42	43.56
3"	10.24	1.81	11.02	1/4"	14.69	5.08	6.30	11.42	69.74
4"	12.87	1.81	13.19	1/4"	17.64	5.08	6.30	11.42	103.40
5"	15.75	1.81	13.19	1/4"	20.98	5.08	6.30	11.42	132.00
6"	16.38	1.81	13.19	1/4"	24.41	5.08	6.30	11.42	170.50
8"	23.62	-	-	-	-	-	-	-	-

Standard Version w/o stroke limiter and manual override

Parts List  
Manual Valve compl.

**Standard Version** (Picture showing DN 80 PN16, PFA-lined, with handwheel)

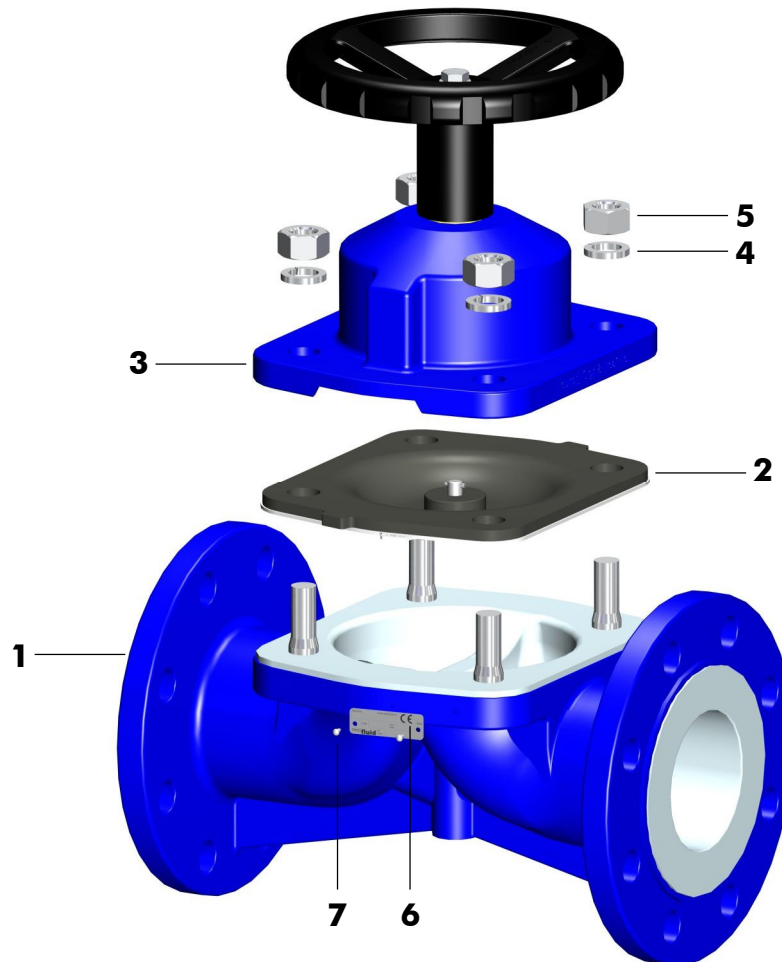

Item	Qty.	Description	Material	No.
1	1	Body PFA-lined, RAL 5005	WCB	1.0619
2	1	Diaphragm complete	PTFE/EPDM	
3	1	Bonnet complete RAL 5005, with handwheel RAL 9004	WCB	1.0619
4	4	Spring Washer	A2	1.4310
5	4	Hex. Nut	A2-70	1.4310
6	1	Name Plate 42 x 14 CE	A2	1.4301
7	2	Hammer Screw 2.49 x 4.76	A2	1.4310

Parts List

Bonnet compl.

**Standard Version** (Picture showing DN 80, with handwheel)

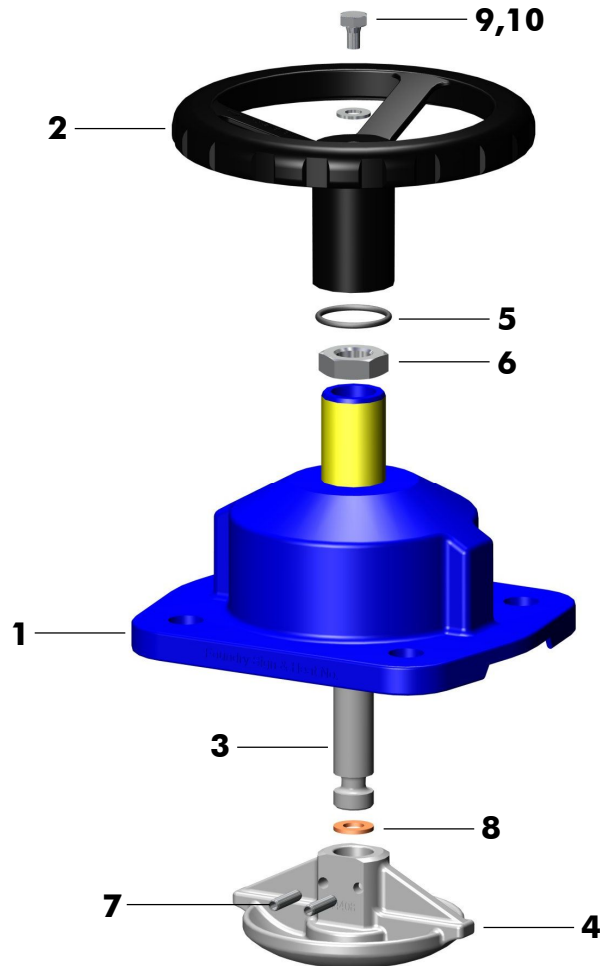

Item	Qty.	Description	Material	No.
1	1	Bonnet, RAL 5005	WCB	1.0619
2	1	Handwheel, RAL 9004	WCB	1.0619
3	1	Spindle	A2	1.4021
4	1	Compressor Plug Bayonet	CF-8M	1.4408
5	1	O-Ring Handwheel	NBR	
6	1	Hex. Nut	A2	1.4310
7	2	Spring Tension Pin	A2	1.4310
8	1	Spacer	Ms60Pb	2.0371
9	1	Spring Washer	A2	1.4310
10	1	Hex. Head Screw	A2-70	1.4310

## Parts List

Automated Valve compl.

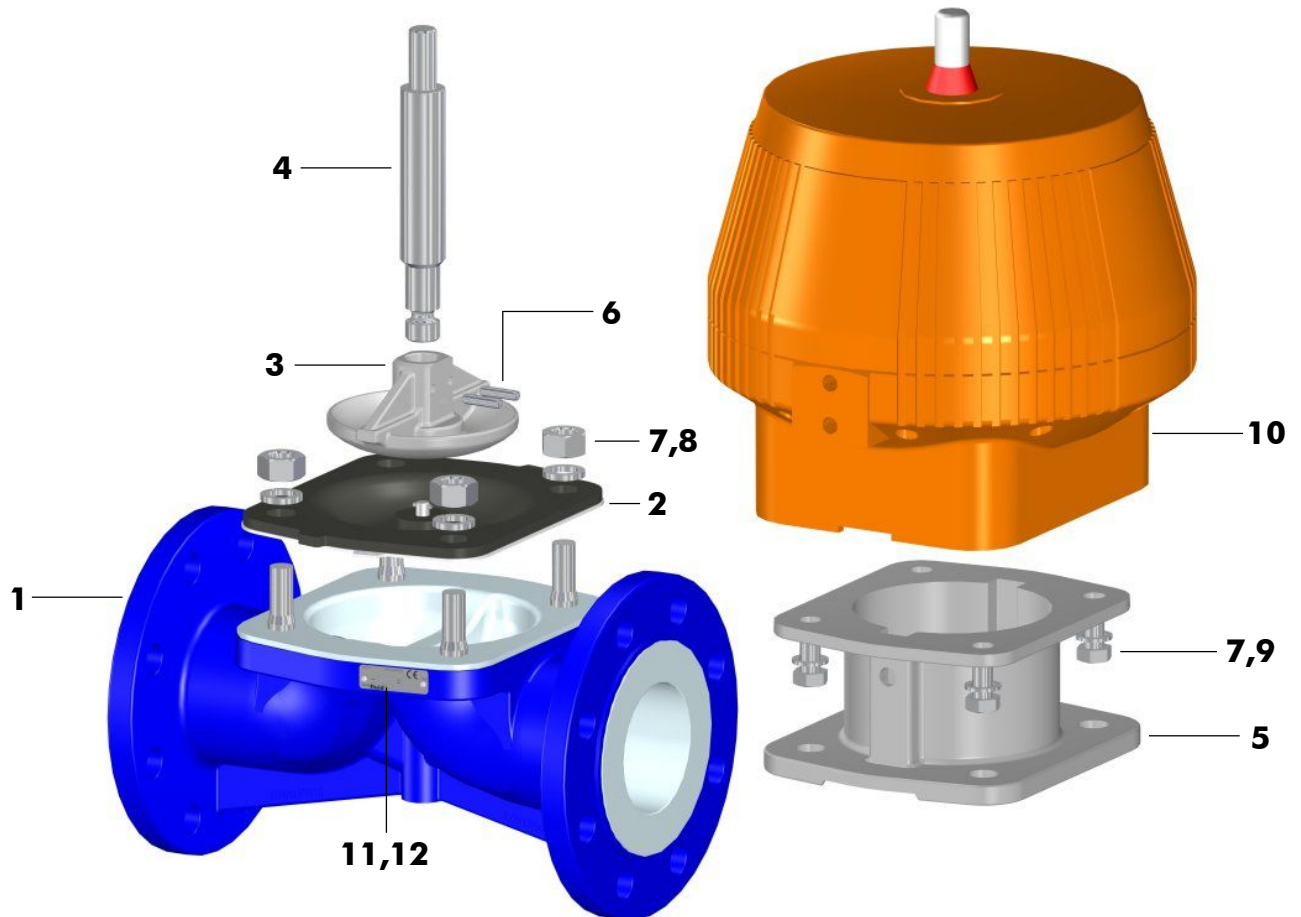
**Standard Version** (Picture showing DN 80 PN16, PFA-lined, with pneum. actuator incl. visual position indicator)

Item	Qty.	Description	Material	No.
1	1	Body PFA-lined, RAL 5005	WCB	1.0619
2	1	Diaphragm complete	PTFE/EPDM	
3	1	Compressor Plug Bayonet	CF-8M	1.4408
4	1	Actuator Spindle	A2	1.4021
5	1	Bracket	CF-8M	1.4408
6	2	Spring Tension Pin	A2	1.4310
7	8	Lock Washer	A2	1.4310
8	4	Hex. Nut	A2-70	1.4310
9	4	Hex. Head Screw	A2-70	1.4310
10	1	Pneumatic Linear Stroke Actuator	PP	SPA-L
11	1	Name Plate 42 x 14 CE	A2	1.4301
12	2	Hammer Screw 2.49 x 4.76	A2	1.4310



Parts List

Valve compl.

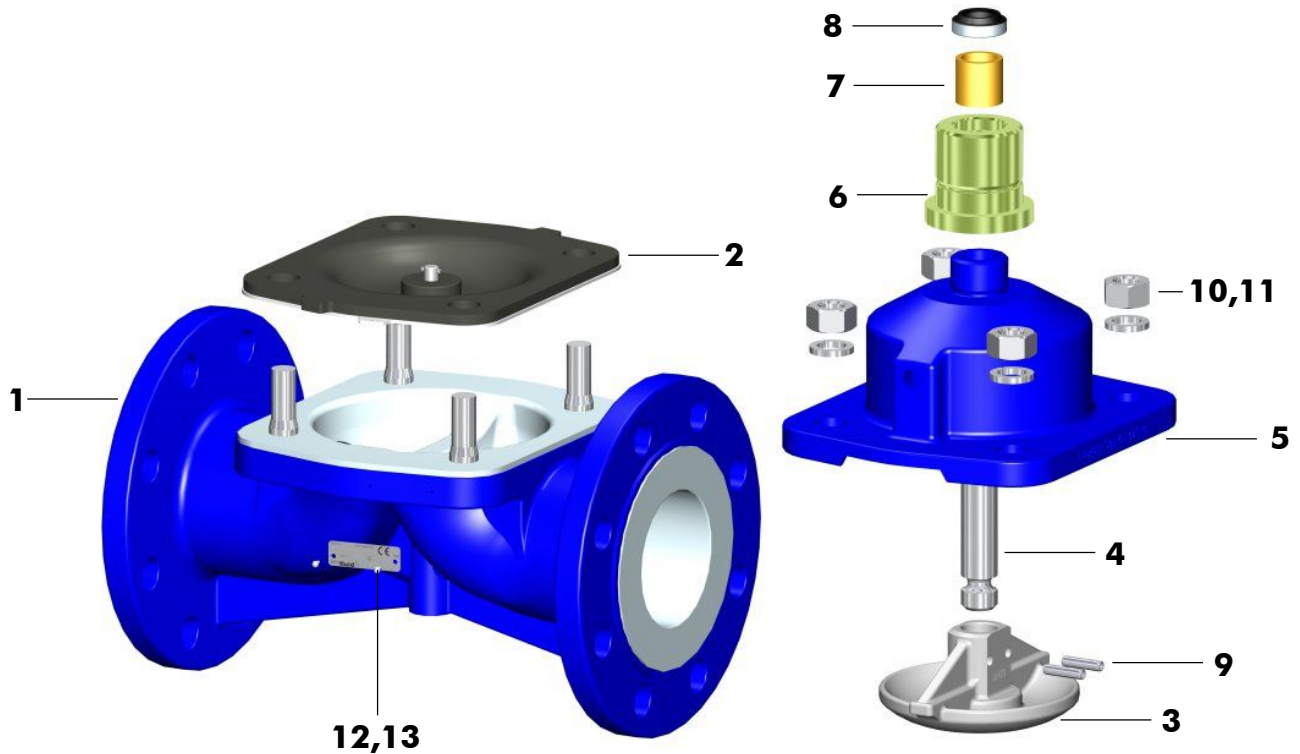
**Standard Version** (Picture showing DN 80 PN16, PFA-lined, with sliding spindle)

Item	Qty.	Description	Material	No.
1	1	Body PFA-lined, RAL 5005	WCB	1.0619
2	1	Diaphragm complete	PTFE/EPDM	
3	1	Compressor Plug Bayonet	CF-8M	1.4408
4	1	Sliding Spindle	A2	1.4021
5	1	Bonnet, RAL 5005	WCB	1.0619
6	1	Threaded Bushing	C.St/galv.	1.0737
7	1	Bushing	Bronze	
8	1	Scraper	St/Nitrile	
9	2	Spring Tension Pin	A2	1.4310
10	4	Lock Washer	A2	1.4310
11	4	Hex. Nut	A2-70	1.4310
12	1	Name Plate 42 x 14 CE	A2	1.4301
13	2	Hammer Screw 2.49 x 4.76	A2	1.4310



## Specification

<b>Project-/Customer Data</b>		Inquiry/Date: _____		<b>Ref. SF</b> _____	
Company:		Contact Person:		Phone:	
Address:		Function:		Fax:	
ZIP/Place:		Department:		E-mail:	
Project:		Phone direct:		Mobile:	

**Operating Conditions**
**Media / Chemical Composition:**

<input type="checkbox"/> liquid	<input type="checkbox"/> powdery	<input type="checkbox"/> crystallizing	<input type="checkbox"/> sticky	<input type="checkbox"/> Spec. Grav. ____
<input type="checkbox"/> gaseous	<input type="checkbox"/> Solids ____ %	<input type="checkbox"/> viscous	<input type="checkbox"/> Flow Velocity ____ ft/sec	
<input type="checkbox"/> abrasive	<input type="checkbox"/> Particle ____ mm	<input type="checkbox"/> Visc. ____ cp	<input type="checkbox"/> Flow Rate ____ usg/min	

**Pressure**

 max. \_\_\_\_ bar  
 min. \_\_\_\_ bar

**Temperature**

 max. \_\_\_\_ °C  
 min. \_\_\_\_ °C

**Mode**
 On/Off  
 Flow Control  
 \_\_\_\_ cycles/ \_\_\_\_

**Installation / Environment**
 horizontal  
 vertical  
 Room dry  
 Room humid  
 outdoor

Remarks:

**SDV Product Code**

## Specification of a complete Diaphragm Valve SDV Series

Product code	Nom. size	Flange conn.	Body	Lining	Diaphragm/ supp. diaphragm	Actuator	Options
<b>SDV</b>	<b>4"</b>	<b>150#</b>	<b>G10</b>	<b>A85</b>	<b>M84</b>	<b>HW</b>	
	½" - 8" DN15 - 150 DN200	ANSI150# ANSI300# PN16 PN10 JIS 10K	G10 WCB G15 CF-8M	A85 PFA A86 PFA-AS A88 PVDF A89 PP A91 ETFE	M83 PTFE/FPM M84 PTFE/EPDM M60 EPDM	HW Handwheel FC Pneum. FC FO Pneum. FO DA Pneum. DA Ss Sliding stem	RAL... special paint B7 B7 body bolts

Note: Actuator options and accessories to be specified on orders separately.